

the collection explores
a contemporary view
of the kitchen space.
technical details and
original layouts inspired
by different moods.

La collezione Ernestomeda:
una concezione della cucina che
coniuga forte caratterizzazione e
massima qualità. Una coerenza
stilistica che si declina attraverso
proposte dalla personalità decisa,
fra dettagli tecnici e originali
abbinamenti materici.

The Ernestomeda collection:
a kitchen concept based on strong
character and top quality. Stylistic
unity interpreted through proposals
with a strong personality created
with technical details and original
combinations of materials.

collection design

by Giuseppe Bavuso

SOUL

01 p. 4

02 p. 24

ICON

01 p. 46

ICONCOLOR

01 p. 64

collection design

R&D ernestomeda

OBLIQUA

01 p. 82

02 p. 102

ONE

01 p. 122

02 p. 136

03 p. 148

collection design

by Giuseppe Bavuso

SOUL 01

Elemento cardine di Soul è il perfetto equilibrio fra funzionalità ed edonismo, che si traduce in soluzioni concrete per chi la cucina la vive come ambiente di lavoro, ma anche come spazio di convivialità. Da un lato, la scelta dei materiali in grado di rispondere ad alti standard di performance e di qualità estetiche, dall'altro soluzioni tecnologiche e di design che semplifichino il lavoro, sia dal punto di vista della preparazione dei cibi che quello del riordino. Il piano cottura è posizionato su una base ribassata ad un livello più ergonomico che rende possibile il controllo del cibo durante la cottura.

La fusione tra spazio cucina e living è resa fluida grazie anche ad elementi modulabili come il sistema di scaffalature Medley - che può essere utilizzato come attrezzatura retrobase o come mobile freestanding e diventa un vero e proprio elemento di continuità con gli spazi attigui se utilizzato come libreria. Cyclos che con il suo piano girevole, a seconda dei momenti della giornata, può trasformarsi da piano snack a vero e proprio tavolo da pranzo.

Soul's key characteristic is the ideal blend of functionality and hedonism, expressed through real solutions for those who use their kitchens not only as working areas but also as places for entertaining. On the one hand, the choice of materials capable of delivering high performance and appearance standards, and on the other, technological and design solutions that simplify tasks, in terms of both food preparation and clearing up.

The hob is at a lower level, more convenient for keeping an eye on food as it cooks.

The fusion of kitchen and living spaces is made more flexible by modular elements like the Medley shelving system - which depending on the chosen layout can be used as a base unit back assembly or as a free-standing sideboard, effectively providing continuity with the adjoining spaces if used as a bookshelf. Cyclos, with its top which revolves to suit the time of day, can be transformed from a snack top to a genuine dining table.

Giuseppe Bavuso

Scopri di più / Find out more
www.ernestomeda.com/soul





Scaffali Medley ad isola: fianchi laccato opaco
Flat Matt Moka, ripiani in vetro riflettente chiaro
con telaio alluminio Rovere Termotrattato,
schienali in vetro riflettente chiaro.

Island Medley shelving system:
Mocha Flat Matt lacquered side panels,
shelves in clear reflecting glass with Heat-Treated
Oak frame, back panels in clear reflecting glass.



Tagliere scorrevole Quick
in Rovere termotrattato
scorrevole su binario.
Utile per la preparazione dei cibi
e come piano d'appoggio, funge
anche da copertura al piano cottura.

Heat-treated Quick sliding
chopping-board
which slides along a rail.
Useful for preparing foods
and as a work-surface,
it can also serve as a hob cover.

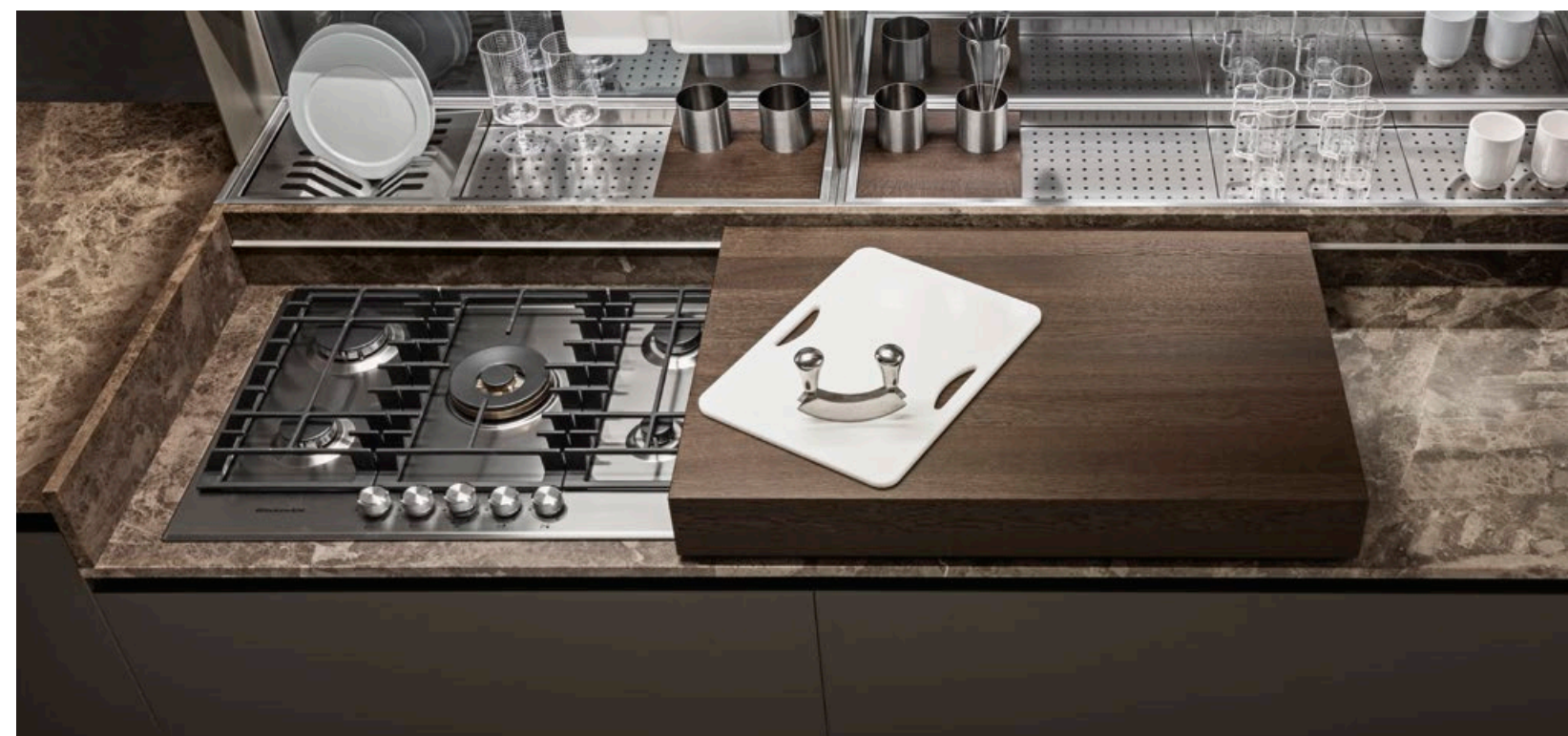
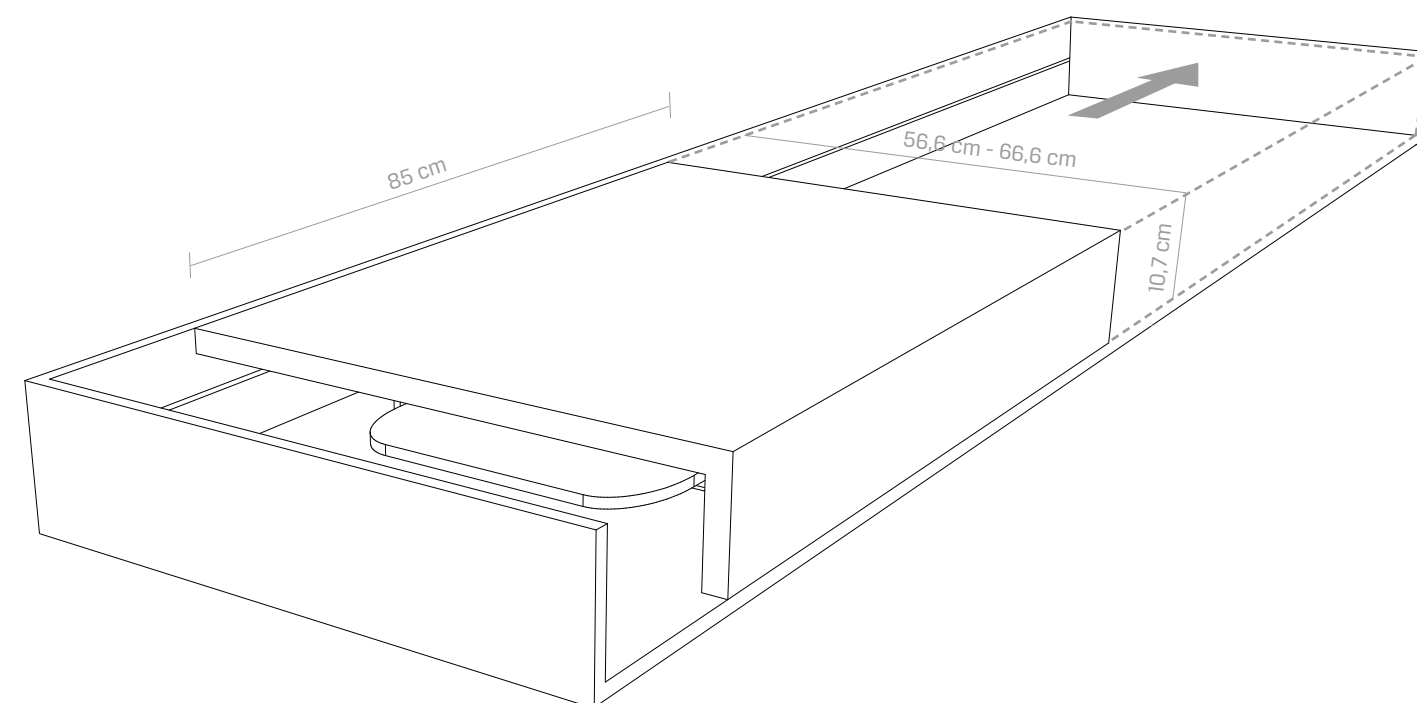

Top, zona lavaggio Bay e alzatina Stand Up in marmo Toffee Brown finitura Leather.

Worktop, Bay washing area and Stand Up upstand in Leather finish Toffee Brown marble.







A sinistra: anta in Olmo Carob.
On the left: door in Carob Elm.

Cappa Skyline:
struttura in acciaio satinato,
versione aspirante,
illuminazione serie Ledline.

Skyline island hood:
satinated steel structure,
ducted version,
Ledline series lighting.

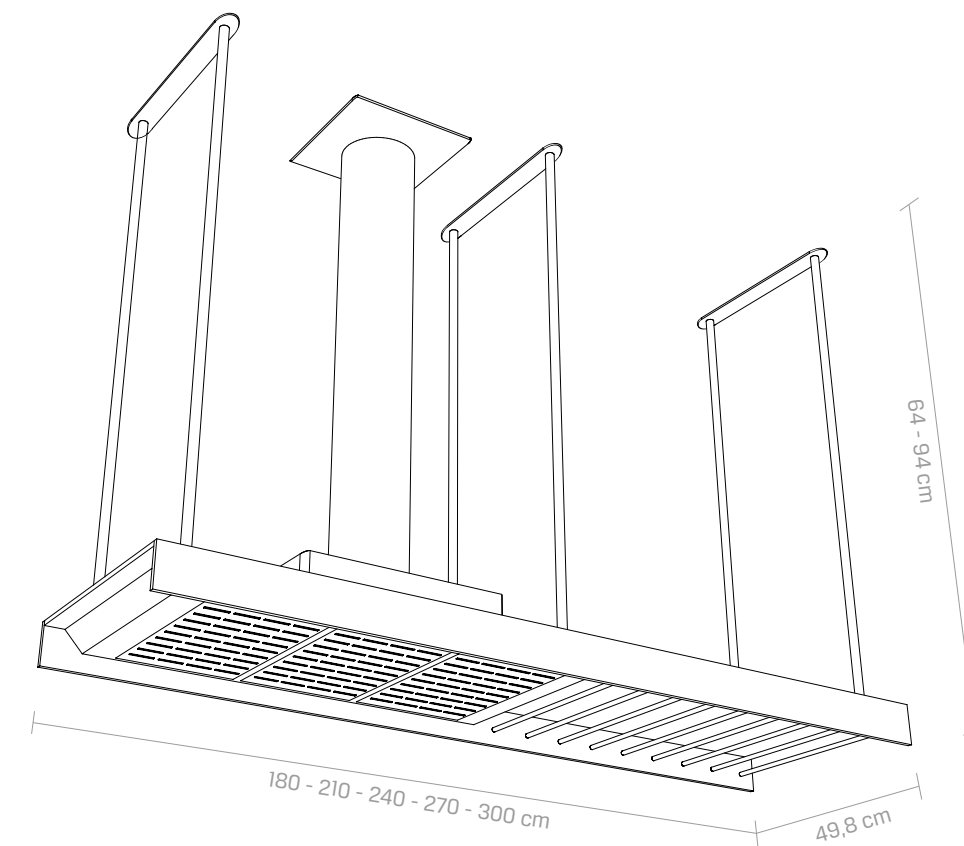

Maniglia Dip: profilo in alluminio integrato nello spessore dell'anta.
Anta e maniglia Dip in laccato opaco Flat Matt Moka.

Dip Handle: aluminium profile integral to the door.
Door and Dip handle in Mocha Flat Matt lacquered.

Anta in Olmo Carob.
Maniglia Dip in laccato effetto metallo Bronzo.

Door in Carob Elm.
Dip handle in Bronze metal effect lacquered.



Tavolo Cyclos: tavolo girevole,
piano in Rovere Termotrattato,
basamento in laccato opaco
Flat Matt Moka.

Cyclos table: revolving table,
top in Heat-Treated Oak,
frame in Mocha Flat Matt lacquered.

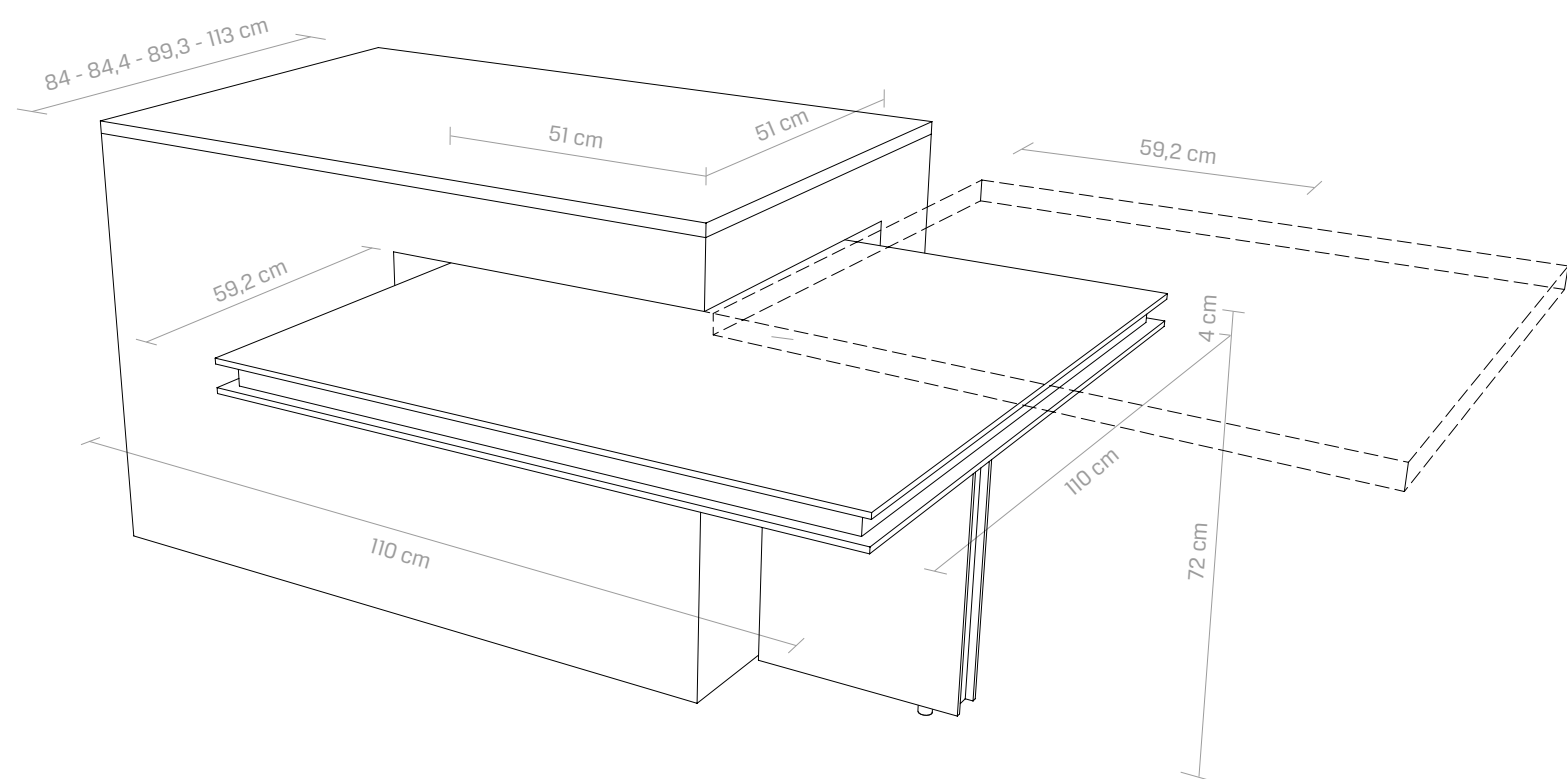

Colonne in laccato effetto metallo Bronzo.
Maniglie Pass in laccato effetto metallo Bronzo.
Interni e schienali Can-Do in Rovere Termotrattato.

Tall units in Bronze metal effect lacquered.
Pass Handles in Bronze metal effect lacquered.
Can-do internal fittings
and back panels in Heat-treated Oak.



SOUL 02

Soul è sinonimo di semplicità e funzionalità nella sua doppia dimensione di ambiente di lavoro e spazio conviviale: dirette emanazioni di questa accezione sono rappresentate dall'ampio monoblocco lavaggio Bay e dal tagliere scorrevole Quick con alzatina Stand Up, a cui si aggiungono piani e basi che danno forma a spazi di lavoro dove tutto è a portata di mano. Soul può essere dotata anche del nuovo Tavolo SteadyTable, contraddistinto da vani a giorno che possono essere accessorati con contenitori di cuoio, funzionali per l'uso in cucina e allo stesso tempo in grado di evocare l'eleganza di uno scrittoio. Soul si caratterizza anche per il pensile In Line con sistema di apertura ergonomico a vasistas, elemento esclusivo Ernestomeda. Facile e leggero da aprire e chiudere, In Line è contraddistinto dalla purezza estetica del movimento, con il meccanismo di apertura e chiusura nascosto nei fianchi, che lo rende un perfetto "anello di congiunzione" tra cucina e living.

Soul stands for simplicity and convenience, with its dual personality as a working environment and a place for spending time with people: this concept is clearly reflected by the large Bay washing monobloc and the Quick sliding chopping-board with Stand Up upstand, together with worktops and base units that create workspaces where everything is in easy reach. Soul may also include the new SteadyTable Table, with open sections which can be fitted with leather containers, convenient for use in the kitchen yet also evoking all the elegance of a writing-desk. Another of Soul's distinguishing features is the In Line wall unit with labour-saving lift-up door, an Ernestomeda exclusive. Easy to open and close with very little effort, the In Line door moves smoothly and elegantly, with the opening and closing mechanism concealed in the side, making the unit the perfect link between the kitchen and living areas.







Basi in laccato opaco Flat Matt Limo.
Maniglie Dip e gola delle basi
in laccato opaco Flat Matt Limo.

Base units in Silt Flat Matt lacquered.
Dip handles and base unit groove strip
in Silt Flat Matt lacquered.





Pensili In Line in laccato
effetto metallo Palladium.
Sistema di apertura/chiusura
dell'anta completamente nascosto
nei due fianchi laterali.
Ripiani Mix, pensili e basi
in vetro grigio trasparente.

In Line wall units in Palladium
metal effect lacquered.
Door opening/closing system
completely concealed
in the two side panels.
Mix shelves, wall and base units
in clear grey glass.

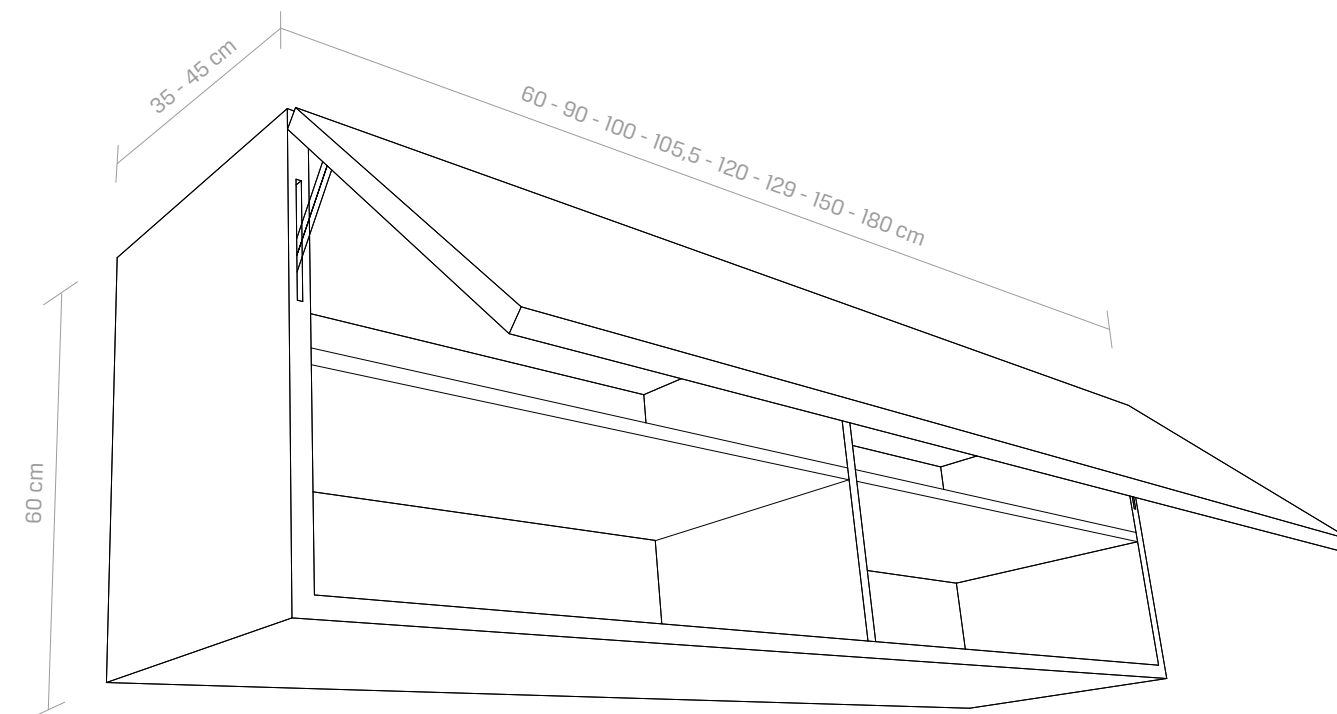

Top, zona lavaggio Bay, alzatina
Stand Up e schienali sottopensile
in marmo Calacatta.

Worktop, Bay washing area, Stand Up
upstand and midway wall cladding
in Calacatta marble.





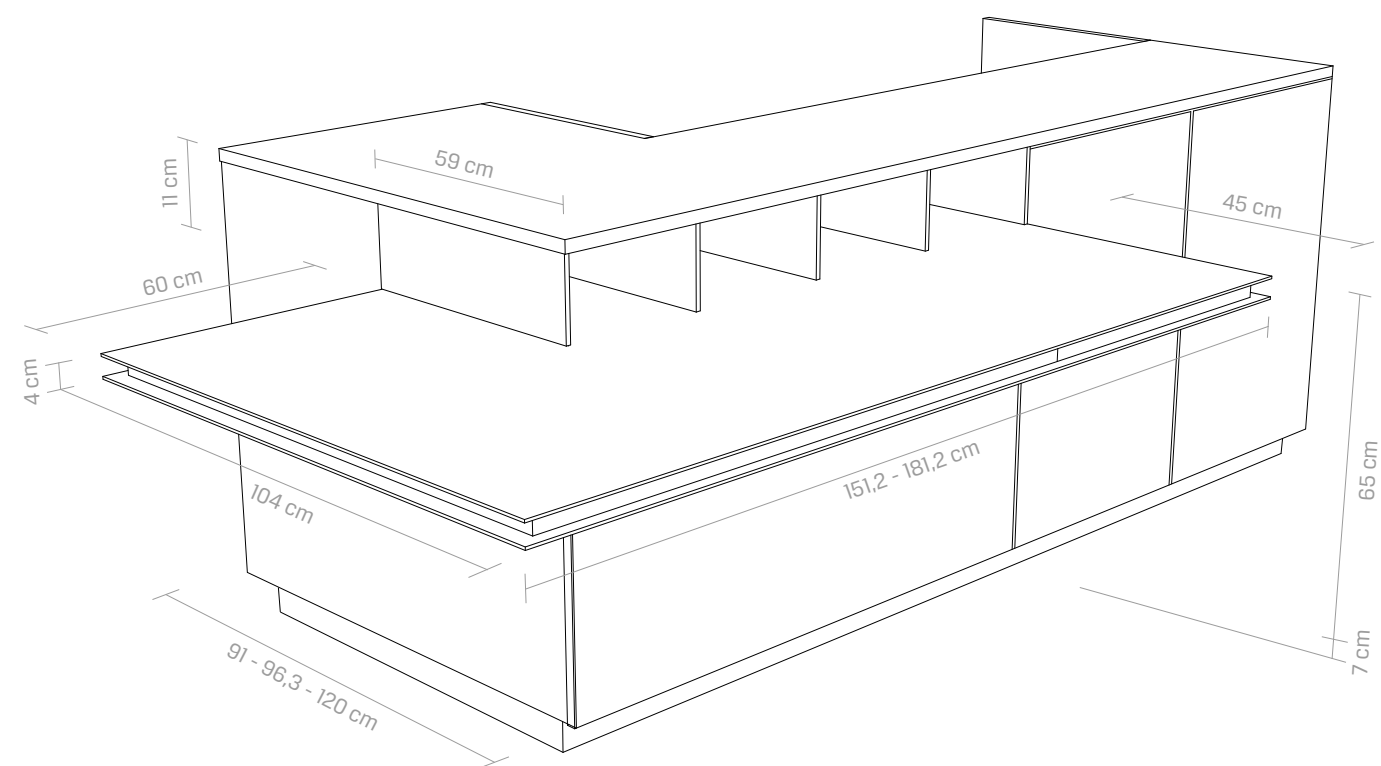

Tavolo Steadytable: tavolo rettangolare in olmo caramel 181x104 cm, altezza da terra pari a 76 cm. Elemento fisso dotato di vani a giorno. Contenitori per tavolo Steadytable in cuoio.

Steadytable table: fixed table in Caramel Elm with open-fronted compartments. Rectangular table 181x104 cm, height 76 cm above the ground. Containers for Steadytable table in leather.



Anta in Olmo Caramel.
Tagliere Quick in Olmo Caramel.

Door in Caramel Elm.
Quick chopping-board in Caramel Elm.



Cappa ad isola Sail:
 disponibile sia nella versione aspirante
 che nella versione filtrante.
 Portata 650 mc/h. Modello Comunitario
 registrato al n. 002013276.

Sail island hood: available
 in extractor or filtering version.
 Motor capacity 650 m³/h (380 cfm).
 Registered community design n. 002013276.

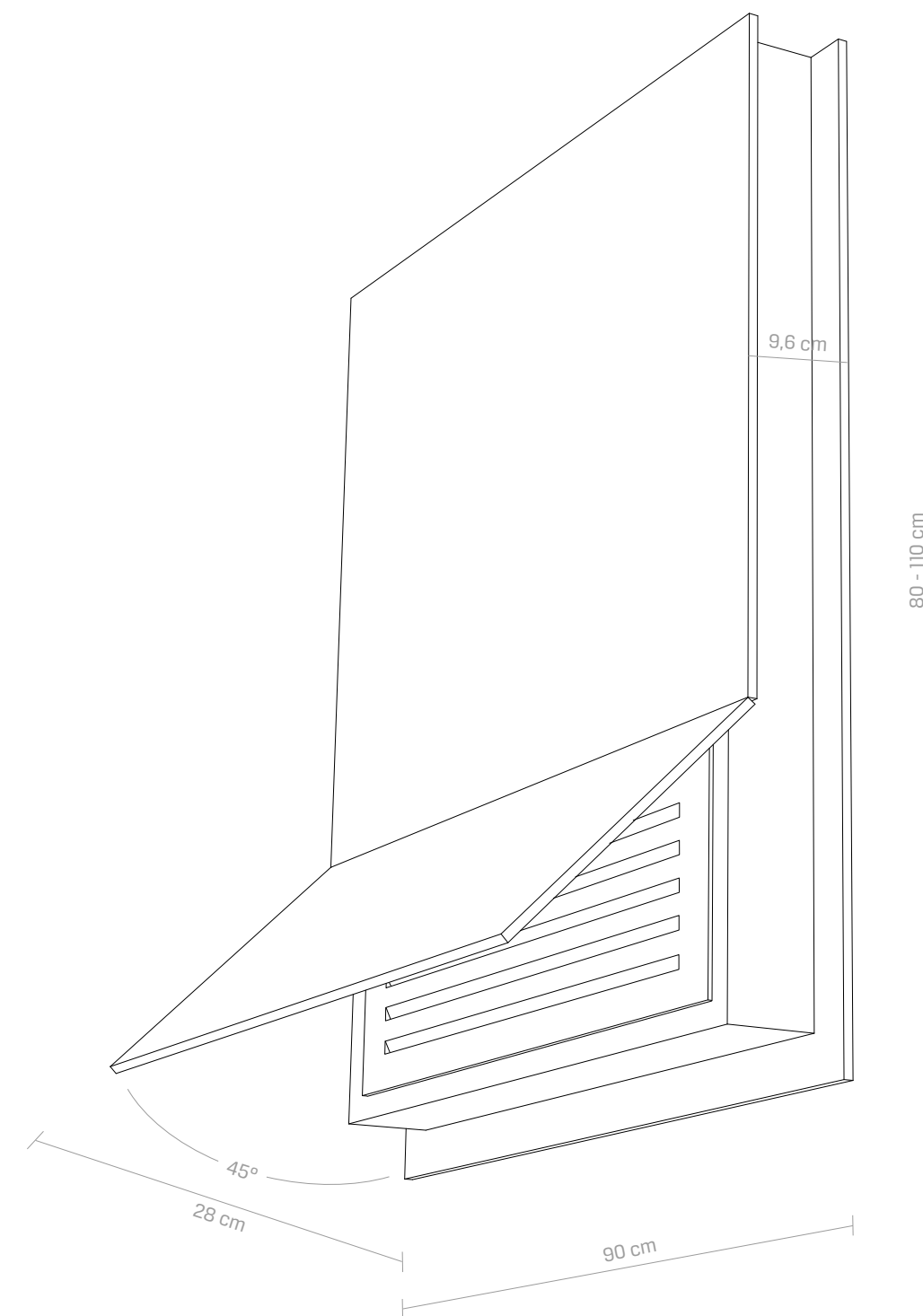

Libreria Medley sotto pensile: fianchi laccato effetto metallo Palladium, schienali in Olmo Caramel, ripiani in vetro grigio trasparente con telaio alluminio laccato effetto metallo Palladium, fondo laccato effetto metallo Palladium, ripiano del fondo in vetro extrachiaro acidato.

Midway Medley bookshelf: Palladium metal effect lacquered side panels, back panels in Caramel Elm, shelves in clear grey glass with Palladium metal effect lacquered frame, bottom Palladium metal effect lacquered, bottom shelf in frosted extraclear glass.



ICON

Le linee guida del Progetto Icon sono state la funzionalità e il design, la pulizia estetica e le prestazioni tecniche.

La cucina concepita come spazio dal design, minimalista ma di grande fascino, connotata da rigore espressivo e da forza emozionale, che fa fronte alle diverse esigenze d'uso, lontana dall'essere un ambiente privo di personalità. Mi piace pensare di riuscire a soddisfare tutte quelle persone che amano la razionalità e la funzionalità dei luoghi senza rinunciare all'anima delle cose.

Con le mie collezioni cerco di rivolgermi ad un pubblico dal gusto contemporaneo e raffinato, che desidera un ambiente molto curato, dove il lusso è da vivere e non da ostentare.

Oltre all'introduzione di diverse soluzioni tecniche innovative, come l'ideazione dell'anta AIR e degli elementi a scomparsa, la ricerca sui materiali è stata fondamentale.

Icon è realizzata con soluzioni di grande valore tecnico e di forte impatto visivo, elementi di finitura in grado di modificare la sensazione di comfort e conferire alla cucina una chiave di lettura non solo estetica ma anche tattile.

The guidelines for the Icon Project were functionality and design, clean aesthetics and technical performance.

A concept of the kitchen as far from lacking in personality, a space for minimalist design yet with great charm marked by the expressive simplicity and emotional force needed to meet the various user expectations. I like to think I succeed in satisfying everyone who loves rationality and functionality without having to give up the heart of things.

With my collections I try to address a public with a refined, contemporary taste that wants a carefully designed room where luxury is for living and not merely to be put on display.

In addition to the introduction of several innovative technical solutions like the creation of the AIR door and the completely integrated elements, the research on materials was fundamental.

Icon has been created using solutions of great technical value and strong visual impact, finishing elements capable of modifying the sense of comfort and giving the kitchen an interpretation which is not only aesthetic, but also tactile.

Giuseppe Bavuso

Scopri di più / Find out more
www.ernestomeda.com/icon





Basi pietra piacentina finitura fiammata.
Mensola Snack Buffet in legno
massello Deluxe rovere vintage.

Base units in flamed finish
piacentina stone.
Snack Buffet shelf in vintage oak
Deluxe solid wood.

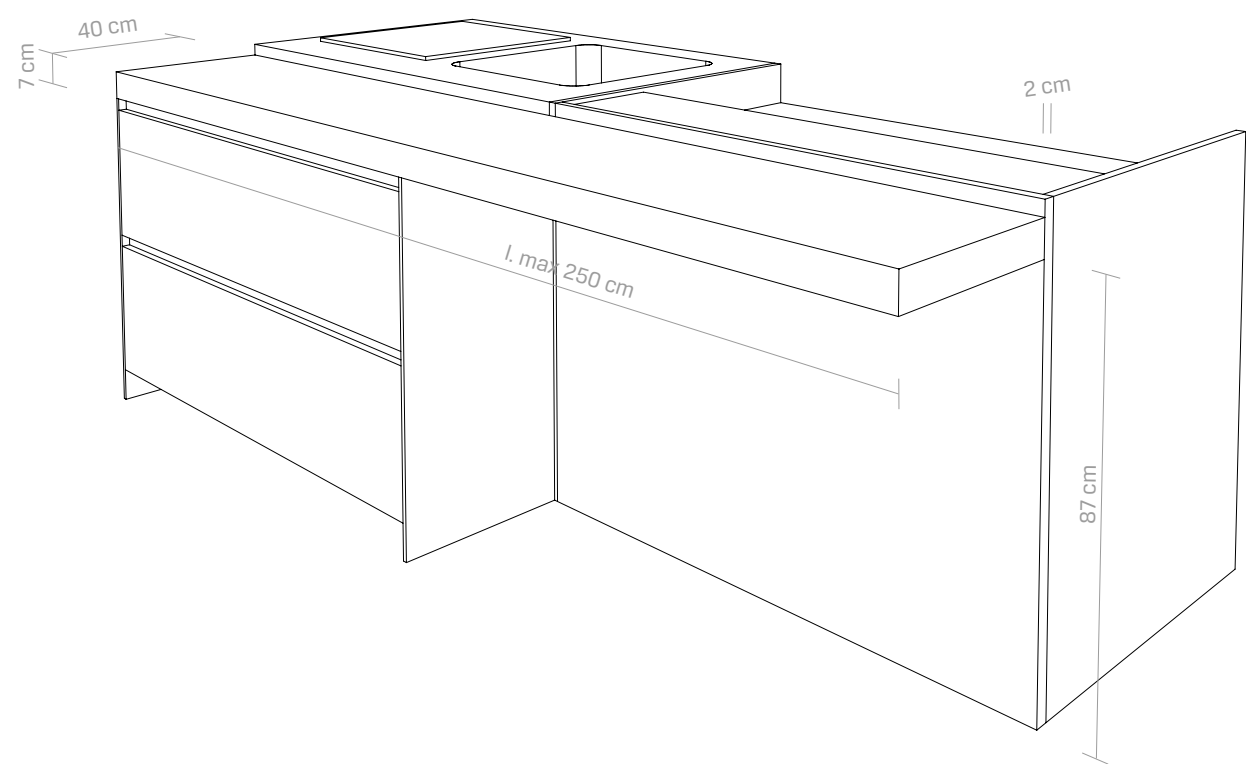



Piano Union con alzatina integrata
in pietra piacentina finitura fiammata.
Monoblocco lavaggio Sequel
in pietra piacentina finitura leather.

Union worktop with integral upstand
in flamed finish piacentina stone.
Sequel sink monoblock
in leather finish piacentina stone.



Cappa ad isola Mistral:
cappa con vetro a tutta altezza.
Disponibile sia nella versione
aspirante che in quella filtrante.
Modello Comunitario registrato
al n. 002013276.

Mistral island hood:
hood with full-height glass.
Available in extractor
or filtering version.
Registered Community design
n. 002013276.

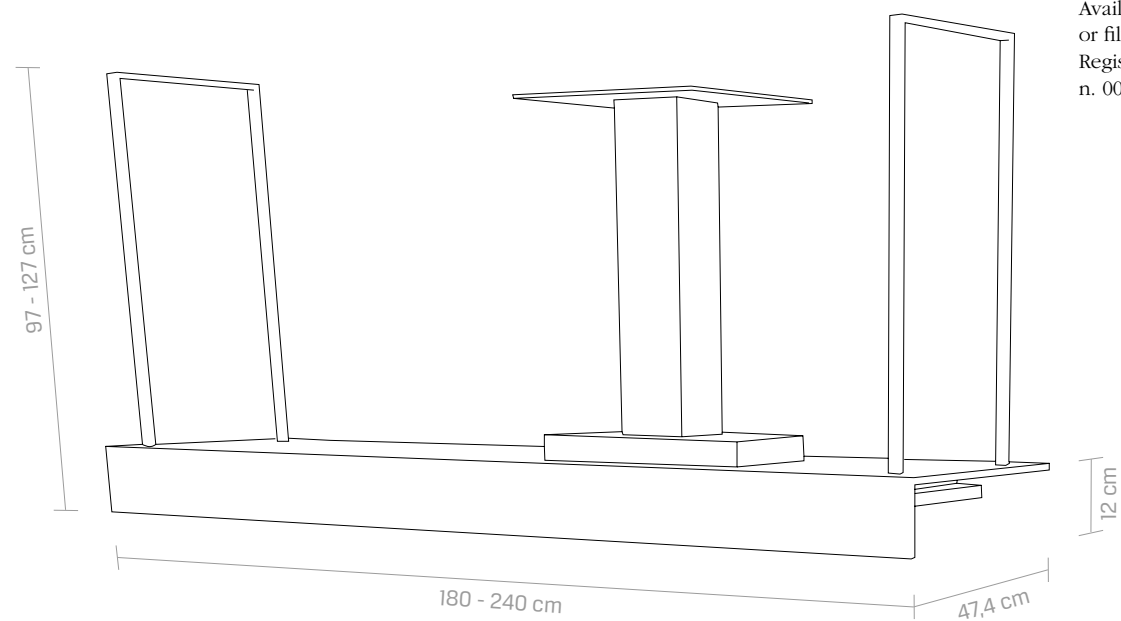



Box forno:
 contenitore in acciaio per l'incasso dei forni
 con larghezza e altezza pari a 61,4 cm
 (forni ad incasso di dimensione standard europeo).
 Il box forno può essere installato sia
 sul pannello boiserie sia direttamente a parete.

Oven container:
 steel container for built-in installation
 of ovens with width and height of 61.4 cm [24 1/8"]
 (european standard built-in oven dimensions).
 The oven container can be mounted either
 on the boiserie panel or on the wall itself.

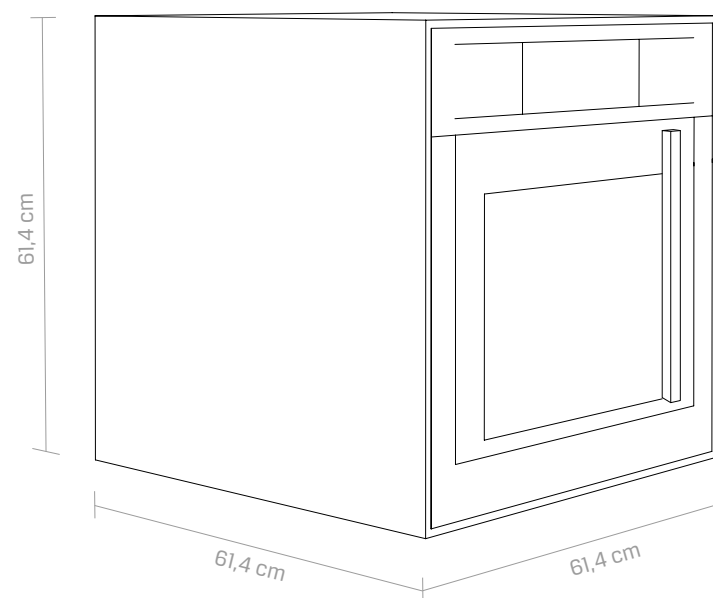

Boiserie laccato opaco Flat Matt moka.
 Mobile sospeso laccato opaco
 Flat Matt moka con piano d'appoggio e alzata
 in pietra piacentina finitura fiammata.

Boiserie in mocha Flat Matt lacquered finish.
 Wall-mounted cupboard in mocha Flat Matt
 lacquered finish with flamed finish
 piacentina stone top and upstand.





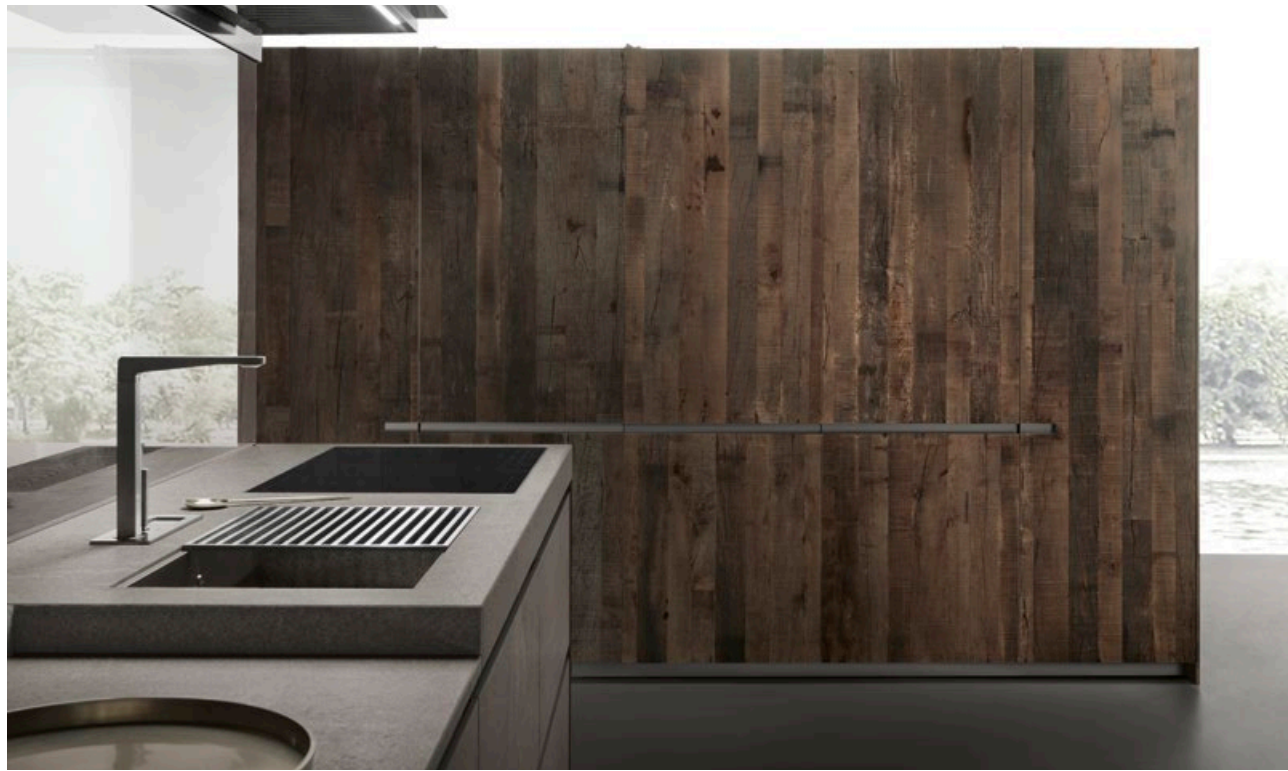

Armadio Indoor in legno massello Deluxe
rovere vintage con cassettera in acciaio.

Indoor Cupboard in vintage oak Deluxe
solid wood with steel drawer unit



ICONCOLOR

Icon giunge oggi alla sua terza evoluzione - IconColor - che rende il modello più flessibile, in particolare nella personalizzazione delle parti in alluminio, finora disponibili nell'unica finitura anodizzato Argento. Con IconColor, Ernestomeda ha messo a punto un processo di sviluppo e realizzazione tecnica esclusivo e brevettato, frutto di una lavorazione complessa, che renderà Icon poliedrica ed eclettica: sarà infatti possibile ottenere ora la personalizzazione degli elementi in alluminio nei cinquanta colori disponibili per le varianti Laccato Lucido Glossix e Laccato Opaco Flat Matt, creando così molteplici combinazioni di colori tra anta e telaio e connotando elementi estremamente tecnici di un'aura calda e contraddistinta da note rassicuranti.

Icon now appears in its third evolution - IconColor - which enhances this model's versatility, especially in the customisation of the aluminium parts, previously only available in the Silver anodised finish. With IconColor, Ernestomeda has developed and patented an exclusive technology involving a complex process, which will make Icon multi-faceted and eclectic. The aluminium elements can now be customised in the fifty colours available for the Glossix Gloss Lacquered and Flat Matt Lacquered finishes, creating infinite colour combinations between door and frame and giving even the most technical items a warm, reassuring aura.





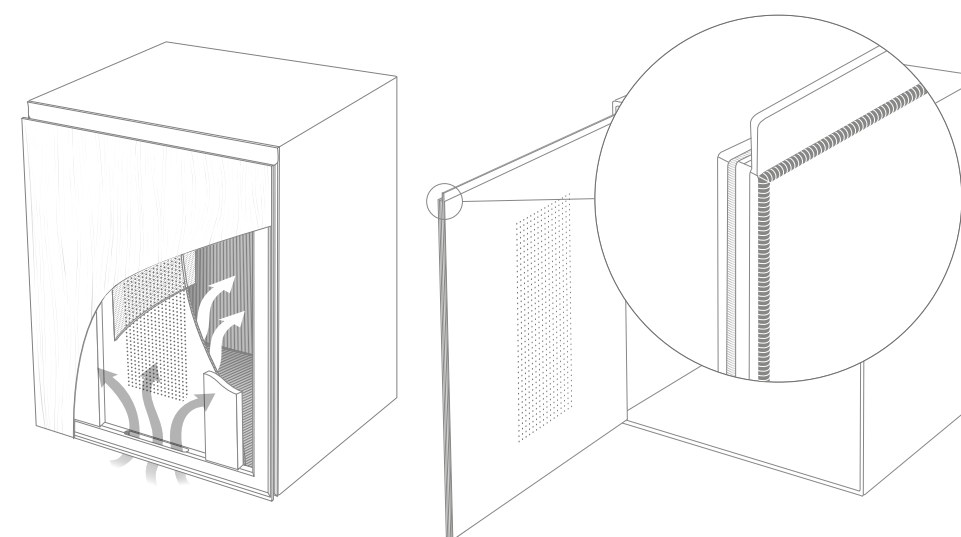

L'anta AIR è dotata di un filtro di aerazione nel lato non a vista (bordo inferiore per le ante di basi ed armadi, bordo superiore per le ante dei pensili) e di fori nel pannello interno dell'anta. Grazie al filtro applicato, l'aria che penetra nel vano è più pulita.

Anta Air telaio e pannello interno in alluminio laccato effetto metallo Umber.

The AIR door has a ventilation filter in the concealed edge (bottom edge for the doors of base units and cupboards, top edge for wall unit doors) and holes in the door's internal panel. Thanks to the filter fitted, the air entering the interior is cleaner.

Air door with frame and internal panel in Umber metal-effect lacquered aluminium.





Penisola estraibile Evolution:
 il tavolo ad isola o penisola scorrevole
 è un elemento caratterizzante
 del programma Icon.
 Evolution è personalizzabile in molteplici
 materiali e finiture e utilizzabile
 come zona snack in versione chiusa
 e tavolo da pranzo in versione aperta.
 Disponibile nei seguenti materiali:
 ICONcrete, quarzo, legno, Corian®,
 pietra piacentina, gres porcellanato.
 Il tavolo è previsto anche
 in versione fissa Annex.

Penisola Evolution con struttura
 in alluminio laccato effetto metallo Umber.

Evolution pull-out peninsula:
 the sliding table (for island
 or peninsula versions) is a key item
 in the Icon range.
 Evolution can be personalised
 in a wide range of materials and finishes
 and is ideal as a snack top in closed
 version or as a dining table when open.
 Available in the following materials:
 ICONcrete, quartz, wood, Corian®,
 piacentina stone, porcelain stoneware.
 The table is also available
 in the Annex fixed version.

Evolution Peninsula with Umber
 metal-effect lacquered aluminium structure.

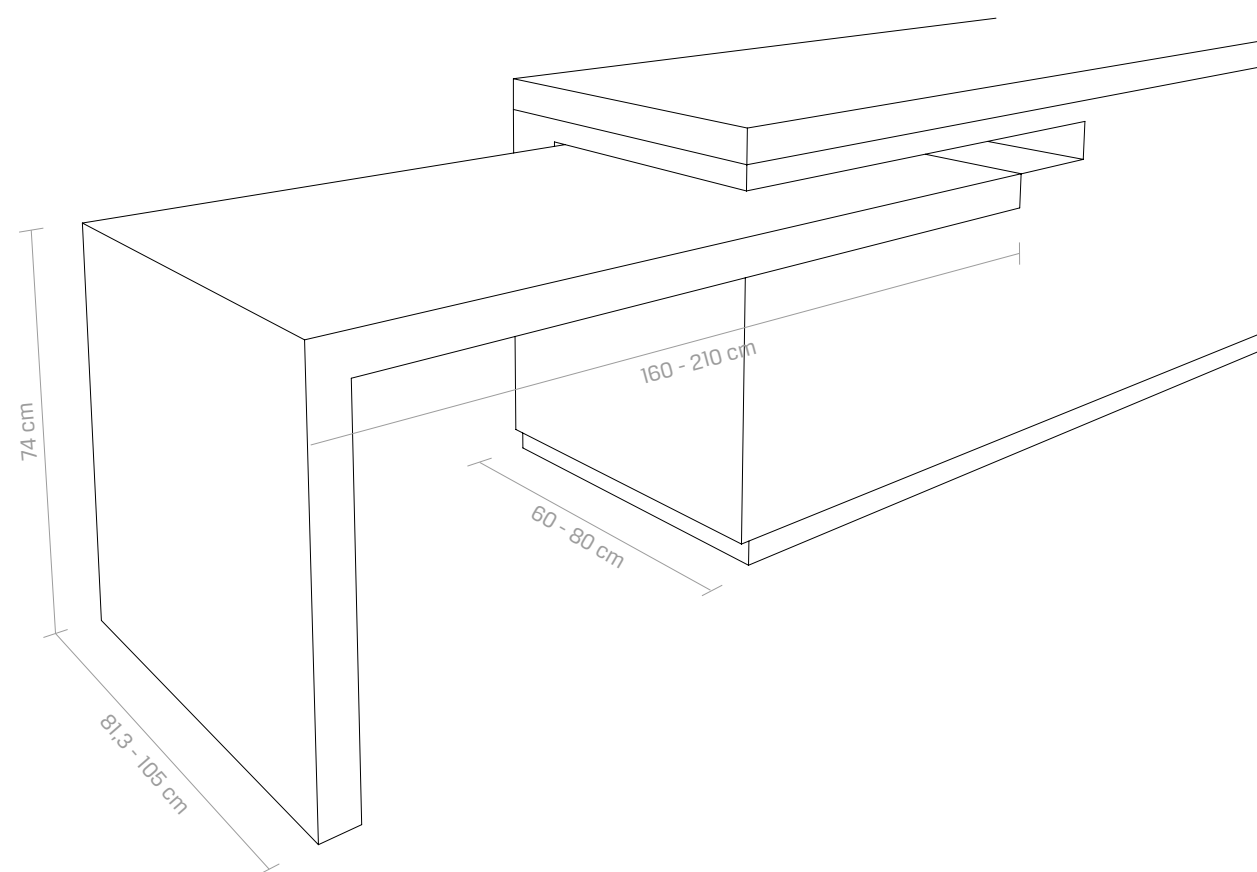

La zona lavaggio Sequel
è progettata per conferire continuità
a tutta l'area e realizzata interamente
nello stesso materiale del top:
ICONcrete, quarzo, acciaio,
Corian®, pietra piacentina e l'esclusivo
materiale porcellanato Stone+.

The Sequel washing area
is designed to give continuity
to the whole area and is constructed
entirely in the same material
as the worktop: ICONcrete, quartz,
steel, Corian®, piacentina stone and
the exclusive porcelain material Stone+.



Top in Stone+ finitura Atmosphere Autumn:
Stone+ è un esclusivo materiale porcellanato
ideale per i rivestimenti della cucina.
La pasta compatta dura, colorata
e non porosa di cui è composto
rende la superficie igienica e perfettamente
idonea al contatto con gli alimenti.

Worktop in Stone+ with Autumn Atmosphere
finish: Stone+ is an exclusive porcelain material
ideal for the finishes of kitchen units.
Its hard, coloured, non-porous body
provides a hygienic surface,
perfectly suitable for contact with foods.



Armadio Indoor:

armadio con ante rientranti Indoor. Elemento dotato di molteplici attrezzature interne: piano d'appoggio e cassetto estraibili, mensole in acciaio, ripiani in alluminio/vetro, portabottiglie e porta bicchieri. Illuminazione Serie Led Line con sensore in apertura e barra elettrificata. Disponibile anche nella versione con elettrodomestici a scomparsa con sistema di sicurezza opzionale "Ernestomeda Safety Oven Switch off". Quest'ultimo è un dispositivo elettronico che in presenza di elettrodomestici integrati all'interno degli armadi, legge ad anta chiusa l'assorbimento della corrente. Superati i 100 W di assorbimento, dopo 90 secondi di avviso acustico, se non viene riaperta l'anta dell'armadio, il sistema spegne automaticamente l'elettrodomestico mettendo il tutto in sicurezza. È possibile personalizzare lo schienale degli armadi in tutte le finiture legno del programma Icon eccetto i legni Deluxe.

Finitura telaio laccato effetto metallo Titanium. Anta rovere terra d'ombra nodato.

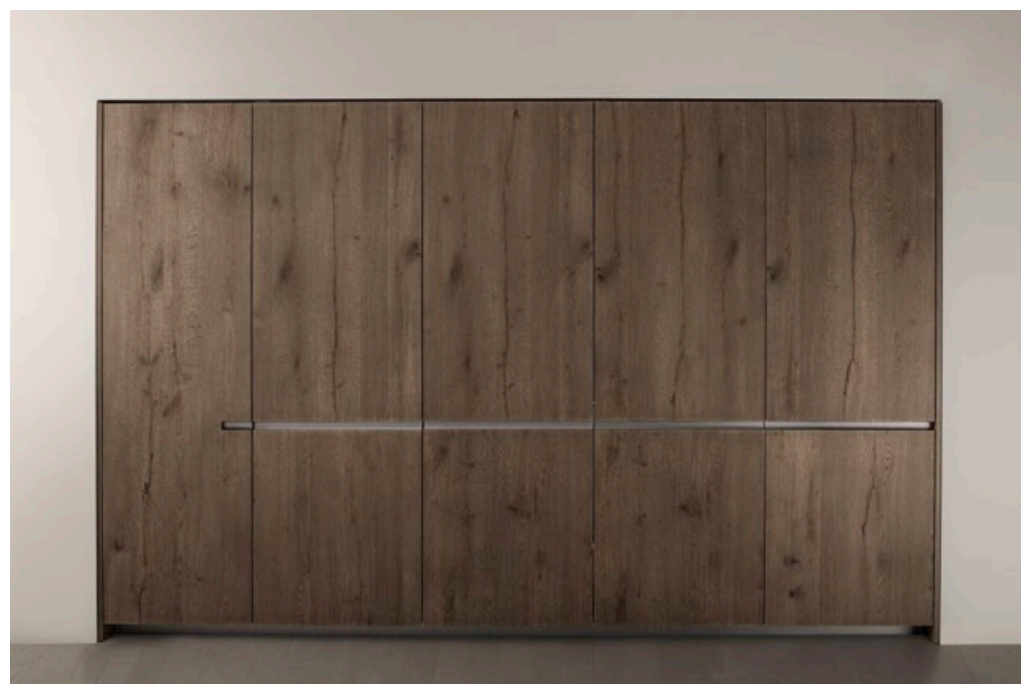
**Indoor Cupboard:**

cupboard with retracting doors. Element with a wide assortment of internal fittings: pull-out table, pull-out drawer, steel shelves, aluminium/glass shelves, bottle rack and glass rack. Led lighting with door opening sensor and power bar. Also available in version with concealed appliances with "Ernestomeda Safety Oven Switch off" optional safety system. This is an electronic device which monitors power absorption when appliances are built into cupboards. Once power absorption exceeds 100 W, if the cupboard door is not opened within 90 seconds of the warning buzzer sounding, the system automatically switches the appliance off for complete safety. The cabinet back panel can be customized in all Icon wood finishes except for Deluxe solid wood.

Frame with Titanium metal effect lacquered finish. Door in knotted terra d'ombra Oak.



collection design

R&D ernestomeda

OBLIQUA 01

È la caratteristica sagomatura a taglio di anta e top a dare il nome ad una cucina equilibrata e innovativa. Il volume è solido e la bellezza degli abbinamenti tra biomalte e legni massello Deluxe la rendono evoluta e accogliente. Il tavolo, connesso all'angolo della base, è un elemento intelligente e di forte personalità.

This elegantly styled, innovative kitchen takes its name from the distinctive oblique shaping of its doors and tops. Its solid volumes and the beauty of the combinations of biomalte and Deluxe solid wood give it modernity and appeal. The table, connected to the corner of the base unit composition, is an intelligent feature with a strong personality.

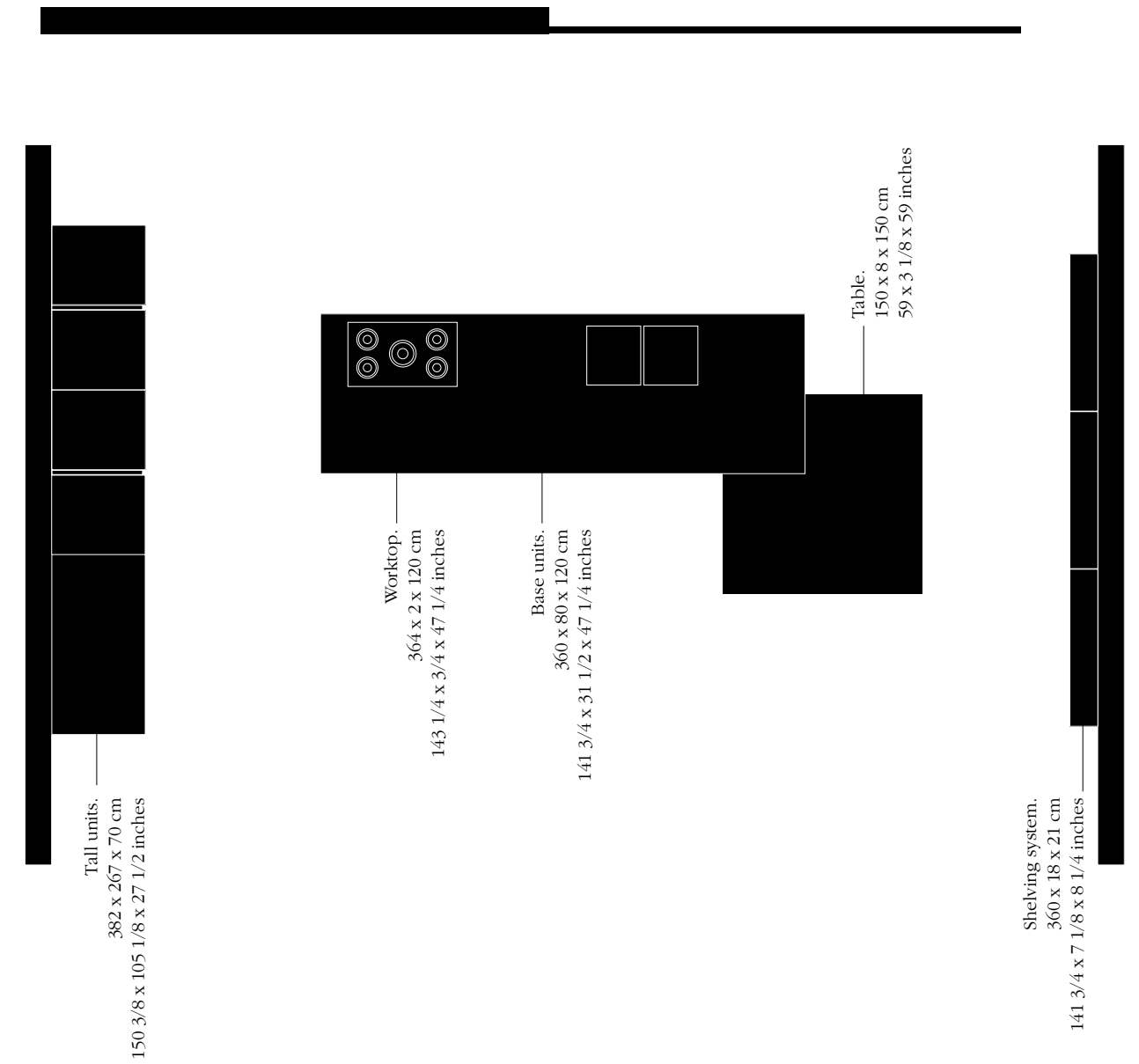





Basi altezza 80 cm e top spessore 2 cm in biomalta castagna, come le gole e gli zoccoli. Colonne in biomalta bianca, gole e zoccoli nella stessa finitura. Tavolo in legno massello Deluxe rovere vintage. Cappa a isola Panel Hood in biomalta castagna.

Base units 80 cm high and worktop 2 cm thick in chestnut biomalta, matching the groove strips and plinths. White biomalta tall units, groove strips and plinths in the same finish. Table in Deluxe solid vintage oak. Island Panel Hood in chestnut biomalta.



Armadio in biomalta bianca,
attrezzato con ripiani Mix
e cassetti interni Legrabox;
schienale personalizzato
in rovere terra d'ombra nodato.
Sistema di illuminazione led line
lungo il fianco della colonna.

Cupboard in white biomalta,
equipped with Mix shelves
and Legrabox inner drawers;
customised back panel
in knotted terra d'ombra oak.
Led Line lighting system
along the side of the tall unit.





Armadio Indoor attrezzato con tavolo estraibile e ripiani in acciaio.
Cestelli in legno massello Deluxe rovere vintage e schienale in terra d'ombra nodato e in acciaio con prese elettriche.

Indoor cupboard fitted with pull-out table and steel shelves. Baskets in Deluxe solid vintage oak and back panel in knotted terra d'ombra and steel, with power sockets.



Tavolo quadrato 150x150 cm
in legno massello Deluxe rovere vintage.
I legni massello Deluxe sono legni
nobili di forte spessore. Nodi, venature,
macchie rossastre, spaccature,
sono tutte irregolarità che determinano
la bellezza naturale della materia.

Square table of 150x150 cm in Deluxe
solid vintage oak. Deluxe solid woods
are thick, choice-grade timbers.
Knots, veins, reddish stains and cracks
are all irregular features that give
this material its natural beauty.



A sinistra: maniglia ad incasso nell'anta frigorifero in biomalta bianca rifinita nello stesso colore e ricavata nello spessore sagomato dell'anta stessa. Sotto: zona lavaggio sottotop e porta rifiuti estraibili per la raccolta differenziata.

Left: handle inset in the refrigerator door in white biomalta finished in the same colour and set into the shaped thickness of the door itself. Below: under-mounted washing zone and pull-out recycling bins.







La biomalta è un materiale innovativo applicato manualmente, testato, collaudato, ecologico e biocompatibile. Vellutata al tatto, si adatta a qualsiasi superficie. Possibili imperfezioni sono da considerarsi un valore aggiunto della messa in posa artigianale.

Biomalta is a hand-applied innovative finish that has been fully tried, tested, ecological and biocompatible. Velvety to the touch, it is suitable for any surface. Any flaws are a value-added feature derived from the hand-application.

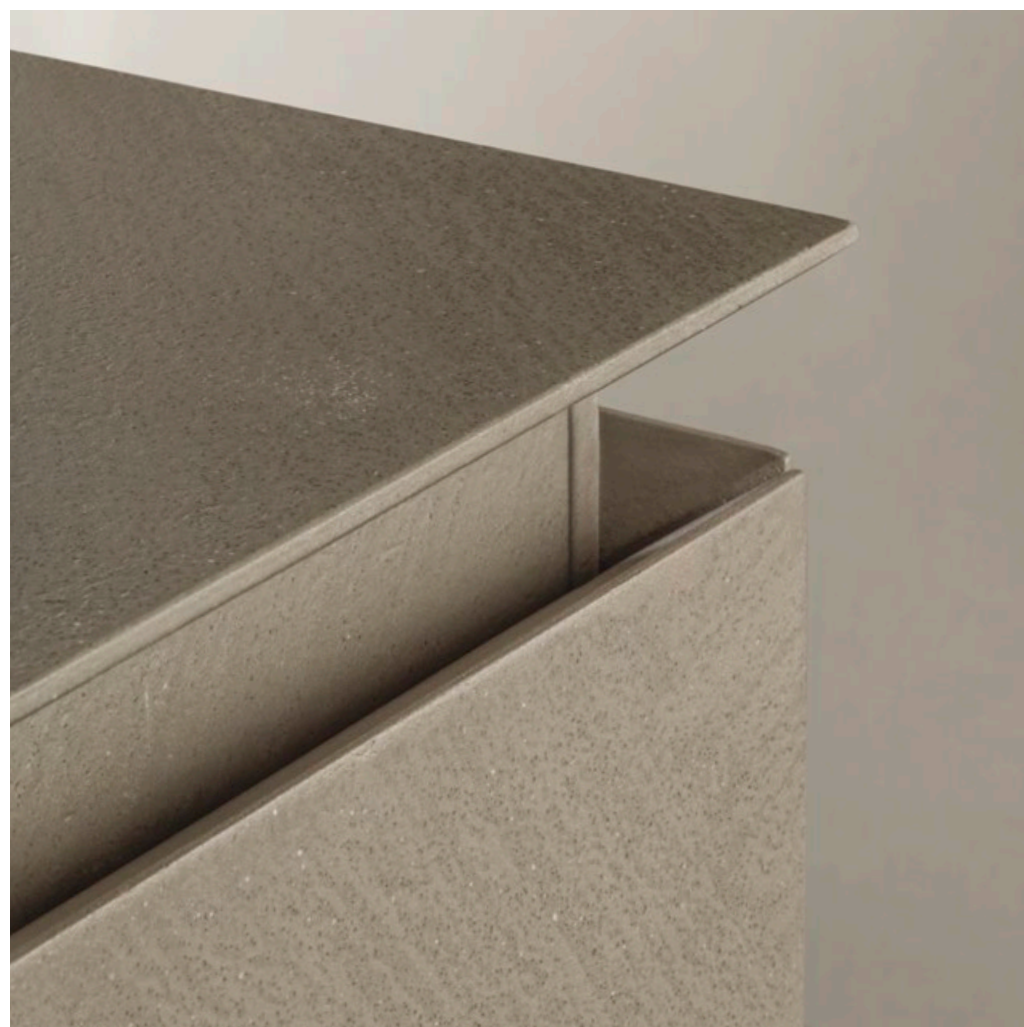

OBLIQUA 02

Compattezza e rigore, per questa composizione. Con la continuità cromatica tra top, gole, ante e zoccoli in unica finitura FenixNTM™, le linee corrono ordinate nello spazio. Il piano snack, in appoggio sull'isola, intervalla la dimensione tecnica con un calda parentesi in legno massello Deluxe rovere quercus.

A compact, impeccably styled composition. With the continuity of colour between the worktops, groove strips, doors and plinths in a single FenixNTM™ finish, the lines run tidily through space. The peninsula snack-top surmounts the system, interrupting the high-tech look with the warmth of Deluxe solid quercus oak.

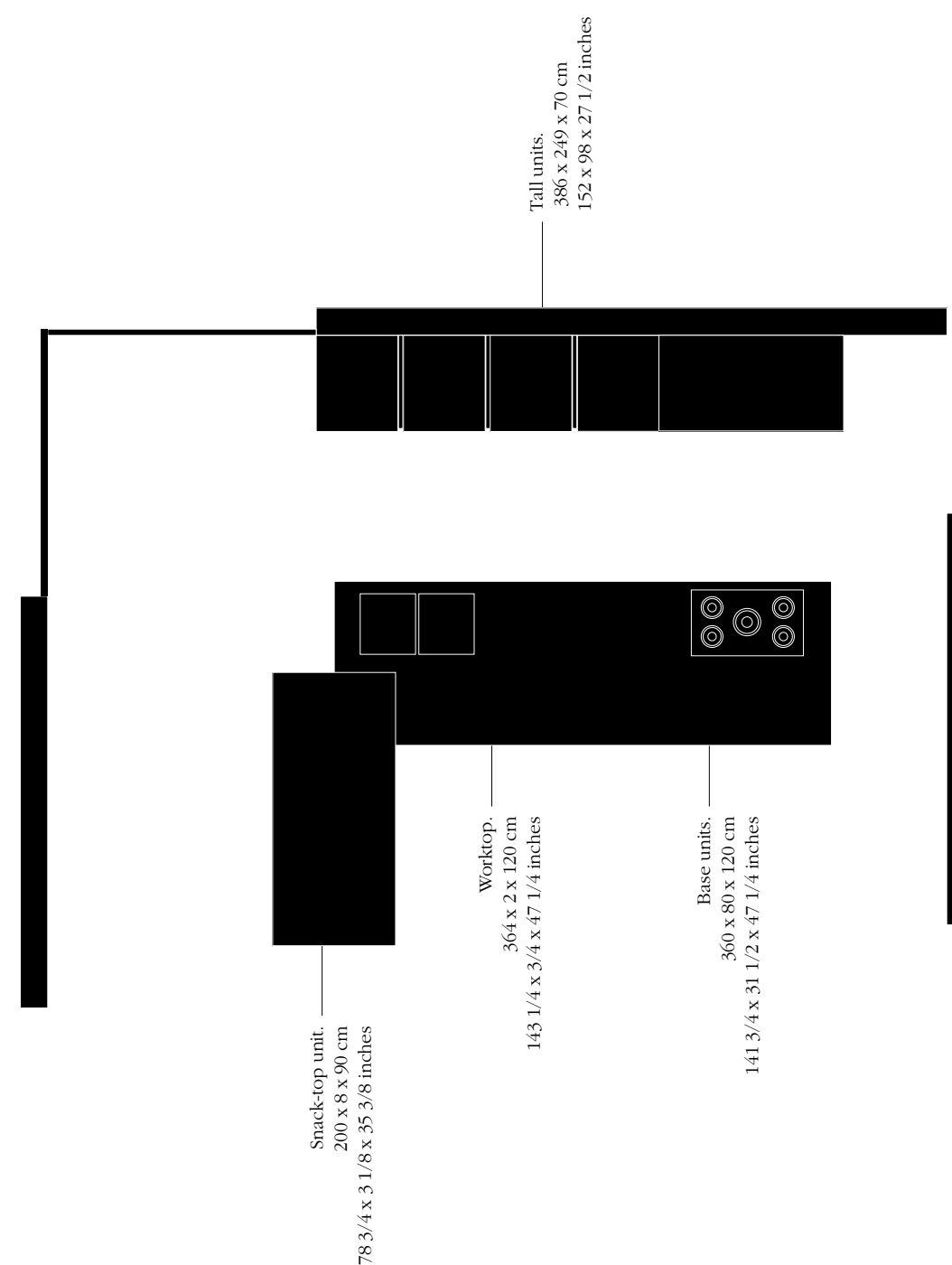



Basi in FenixNTM™ grigio bromo,
gole e zoccoli nella stessa tonalità.
Piano snack in legno massello
Deluxe rovere quercus con sostegno
in laccato tonalità FenixNTM™ grigio bromo.
Colonne in FenixNTM™ bianco kos,
gole e zoccoli nella stessa tonalità.
Cappa Panel Hood a isola
in laccato tonalità FenixNTM™ grigio bromo.

Base units in bromine grey FenixNTM™,
groove strips and plinths in the same shade.
Snack-top in Deluxe solid quercus oak
with support in bromine grey
lacquered FenixNTM™.
Tall units in kos white FenixNTM™,
groove strips and plinths in the same shade.
Island Panel Hood in bromine grey
lacquered FenixNTM™ .



A sinistra: dettaglio del legno massello Deluxe rovere quercus. Questa essenza legno, dalle evidenti caratteristiche materiche, si distingue per i suoi toni caldi e luminosi, valorizzati in un contesto moderno.

Left: detail of Deluxe solid quercus oak. This wood, with its eye-catching tactile characteristics, comes in warm, glowing shades that make an attractive addition to a modern context.







Maniglia ad incasso nell'anta lavastoviglie rifinita nello stesso colore e ricavata nello spessore sagomato dell'anta stessa. A destra armadio Indoor attrezzato con macchina da caffè, cantinetta vini, cestelli in grigio bromo come le ante dell'isola. Ripiani in acciaio.

Handle inset in the dishwasher door finished in the same colour and set into the shaped thickness of the door itself. On the right, Indoor cupboard fitted with espresso machine, wine cellar and baskets in bromine grey to match the doors of the island. Steel shelves.



Sotto: colonne forno con cassetti interni e cestelli estraibili.
Facile apertura grazie alle gole verticali e alla sagomatura dell'anta.

Below: oven tall units with inner drawers and pull-out baskets.
Opening is easy thanks to the vertical groove strips and the shaping of the door.





A sinistra: zona operativa dal design rigoroso, con la gola dei cestoni che continua nel coprifianco.
Sotto: dettaglio degli spessori sottili del profilo.

Left: flawlessly styled working area with the groove strip of the baskets continuing along the side facing panel.
Below: detail of the slimline profile.

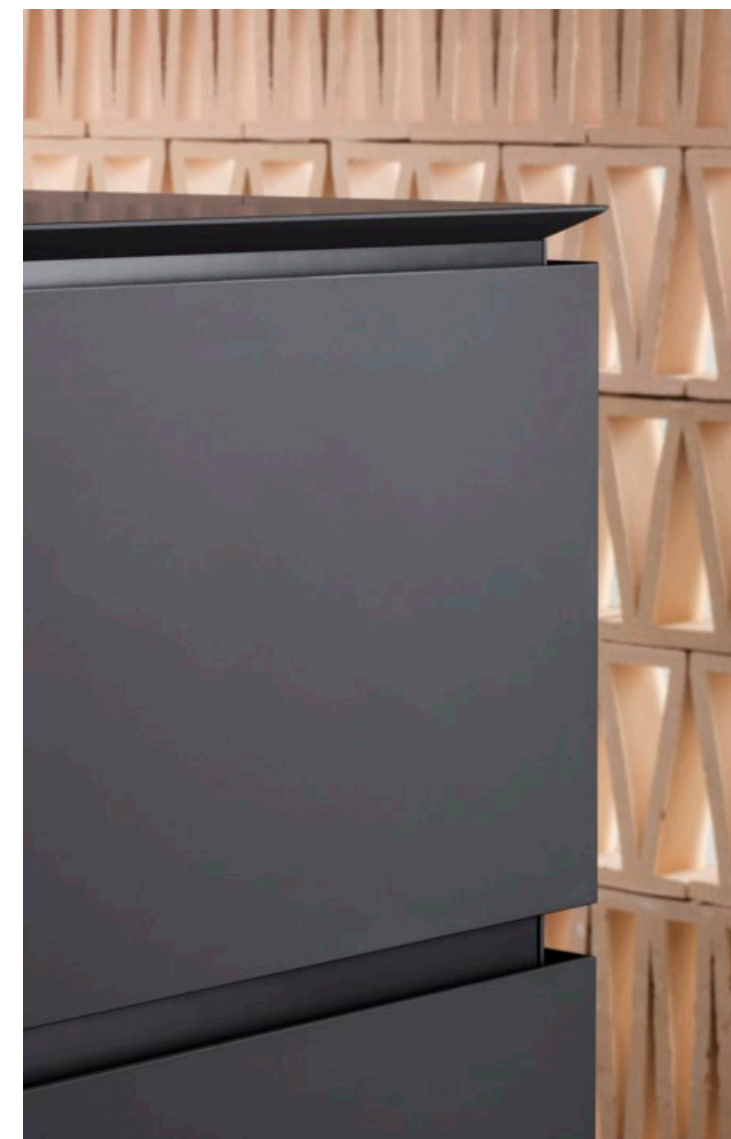

ONE 01

Una composizione a penisola basata su sottili contrasti cromatici e formali. Un materiale ad alto contenuto tecnico, come l'esclusivo Iconcrete, si abbina alla forte sensazione di naturalezza del rovere.

A peninsula composition based on subtle contrasts in colour and form. The exclusive, high-tech Iconcrete combines with the strongly natural feel of oak.

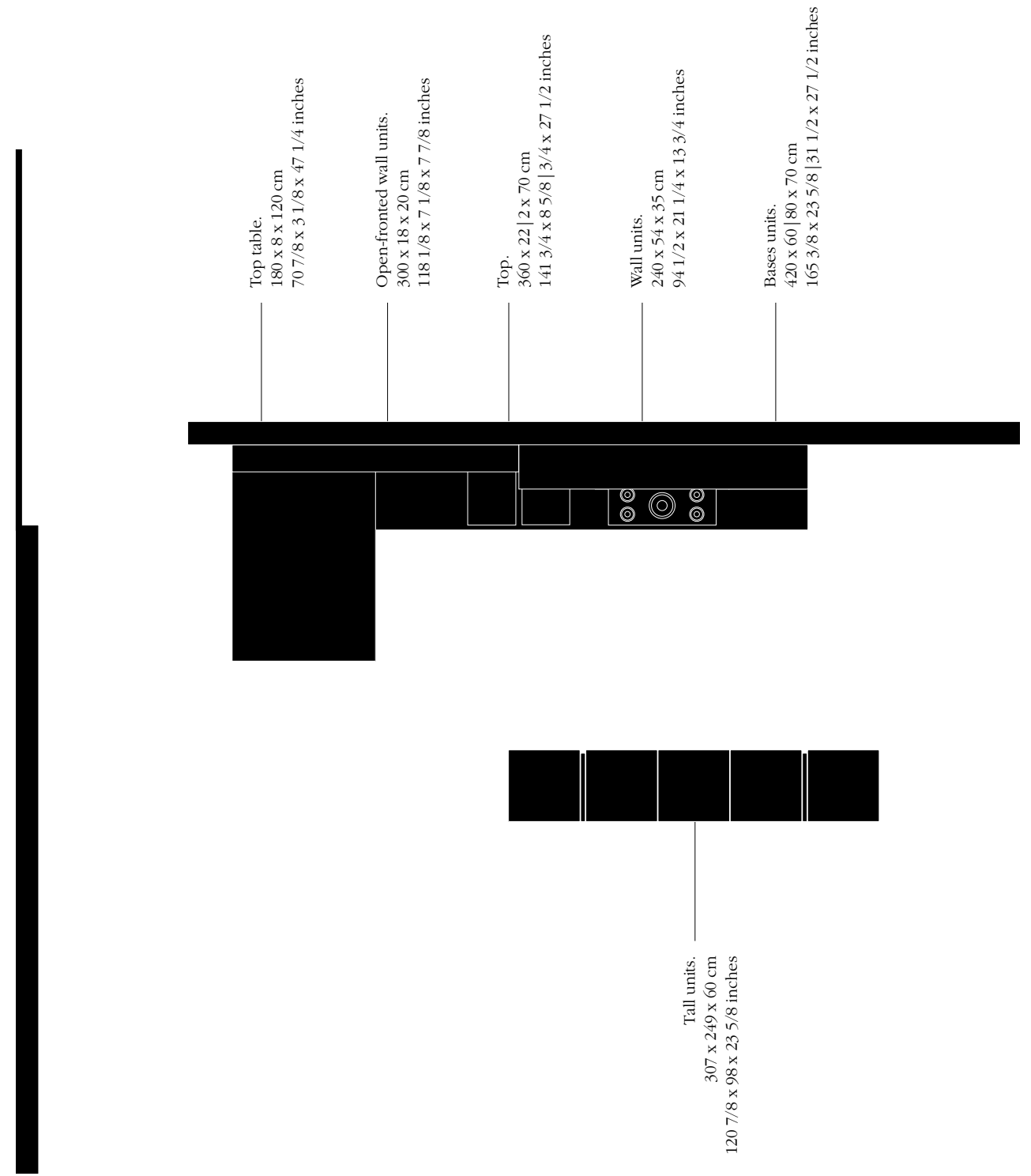



Basi altezza 60 e 80 cm, colonne
e pensile laccato opaco grigio rugiada.
Top e alzata schienale in Iconcrete.
Pensili a giorno laccato lucido corniola.
Penisola con piano in rovere imperial.

Dew matt lacquered base height 60
and 80 cm, tall and wall units.
Worktop and wall cladding in Iconcrete.
Carmelian gloss lacquered open-fronted wall units.
Peninsula with imperial oak worktop.

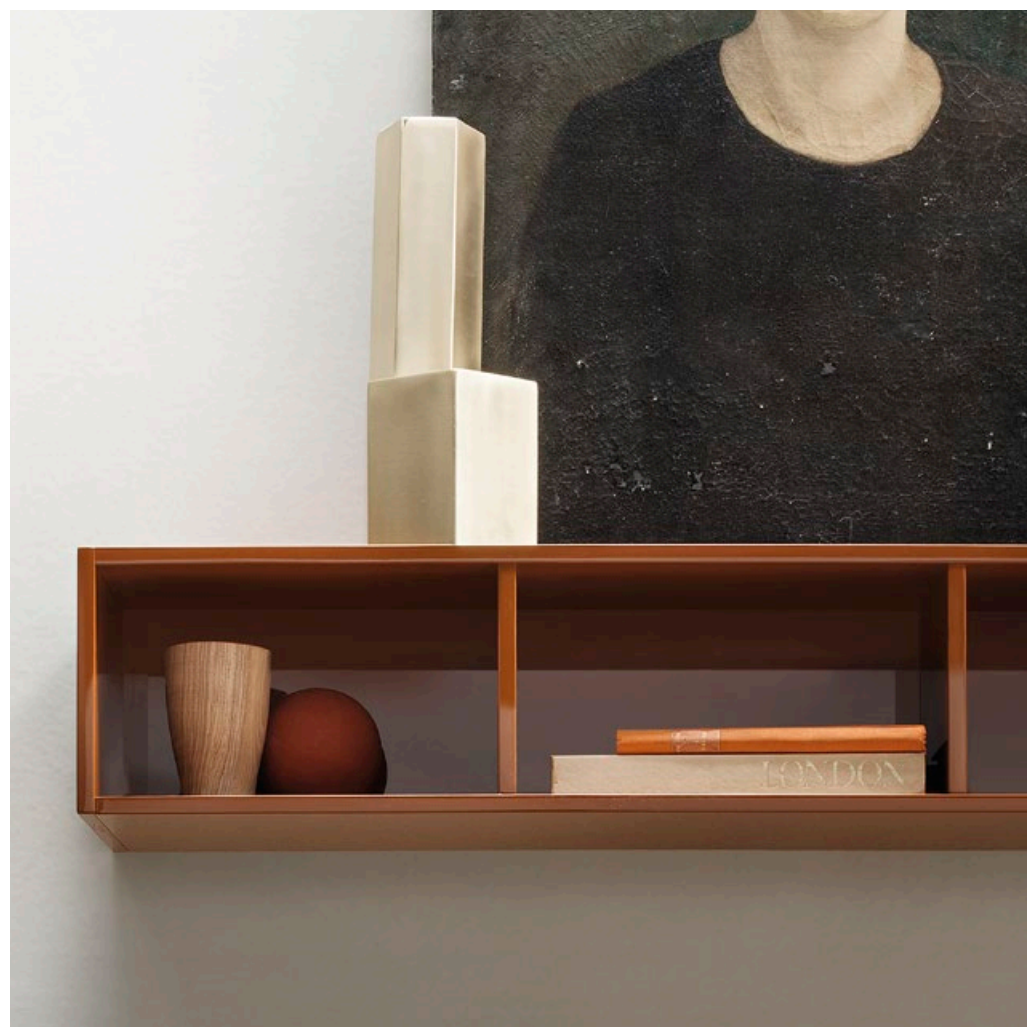





Il top Iconcrete presenta due differenti spessori: il blocco di spessore 22 cm integra le vasche lavello sottotop monomateriche, il blocco di spessore 2 cm il piano cottura in acciaio incassato con griglie filotop.

The Iconcrete worktop is in two different thicknesses: the 22 cm thick block incorporates the undermounted sink in the same material, the 2 cm thick block hosts the built-in steel hob with pan stands at worktop level.







Basi altezza 60 e 80 cm laccato opaco grigio rugiada.
Estrattori con cassetti interni grigio antracite,
attrezzatura interna rovere dark.
Sistema di illuminazione interna serie led line.

Dew matt lacquered base units height 60 e 80 cm.
Nested drawers with anthracite grey
internal sections and dark oak internal fittings.
Led line series internal lighting system.



ONE 02

La cucina in vetro: una nuova interpretazione di ispirazione tecnica. Un layout articolato su due diverse soluzioni ad angolo, in cui diventano protagoniste le ampie superfici del piano in acciaio.

The glass kitchen: a new technology-inspired interpretation. The layout revolves around two different corner solutions centered on the large surfaces of the steel top.

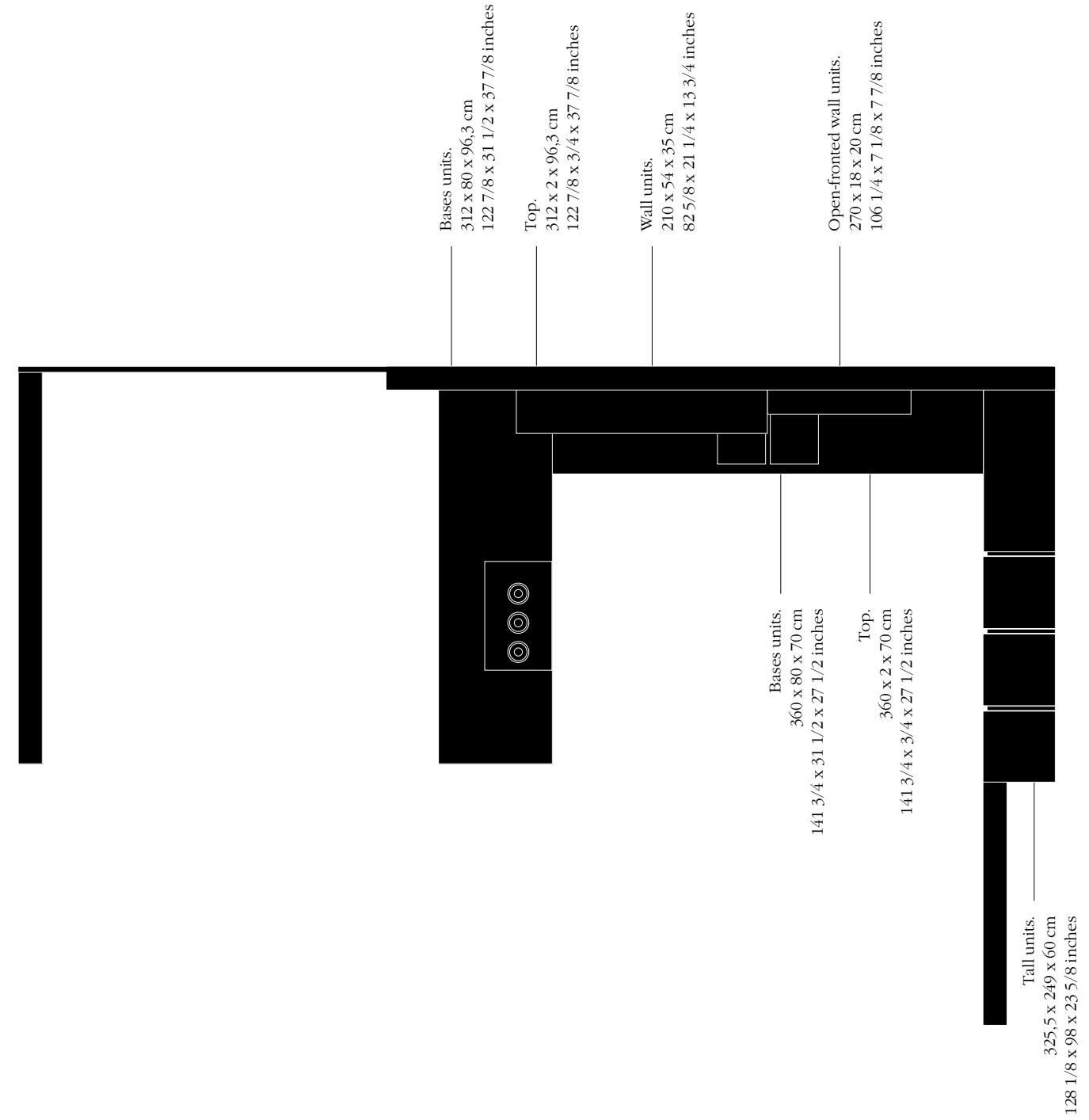



Basi altezza 80 cm, colonne e pensili
in vetro laccato opaco ghisa.
Vani a giorno in hi-melamine bistro.
Top in acciaio satinato spessore 2 cm.
Cappa Wing ad isola in acciaio satinato.
Sotto: dettaglio del piano cottura
saldato con griglie a filo.

Base units height 80 cm, tall and wall
units in matt cast iron lacquered glass.
Open-fronted wall units in bistre hi-melamine.
Top in 2 cm thick satin finish steel.
Wing island hood in satin finish steel.
Below: close-up of the welded hob
with pan stands at top level.





Pagina precedente: estrattori
con attrezzatura interna rovere dark.
A sinistra: lavello in acciaio integrato
nel top, vasche con sistema di deflusso
dell'acqua senza fori a vista.
Sotto: dettaglio dell'anta
con telaio in alluminio e frontale
in vetro laccato opaco ghisa.

Previous page: nested-drawers
with internal fittings in dark oak.
Left: Steel sink built into top;
water outflow system
with no visible drain holes.
Below: close-up of door
with aluminum frame and matt cast
iron lacquered glass front panel.



A sinistra: penisola con ante in vetro laccato opaco ghisa e top in acciaio spessore 2 cm. Cappa Wing in acciaio. Sotto: base ad angolo con cestelli ad estrazione totale.

Left: snack top with matt cast iron lacquered glass fronts and 2 cm thick steel top. Wing hood in steel. Below: corner base unit with full extraction baskets.



ONE 03

Un'isola total white dalla forma primaria, una parete in rovere termotrattato: un'estetica di rigore assoluto cela al proprio interno un'ampia varietà di soluzioni funzionali e operative.

A total white island with a primary shape, cupboards with heat-treated oak fronts: stark simplicity of design on the outside, with a wide variety of functional and working solutions on the inside.

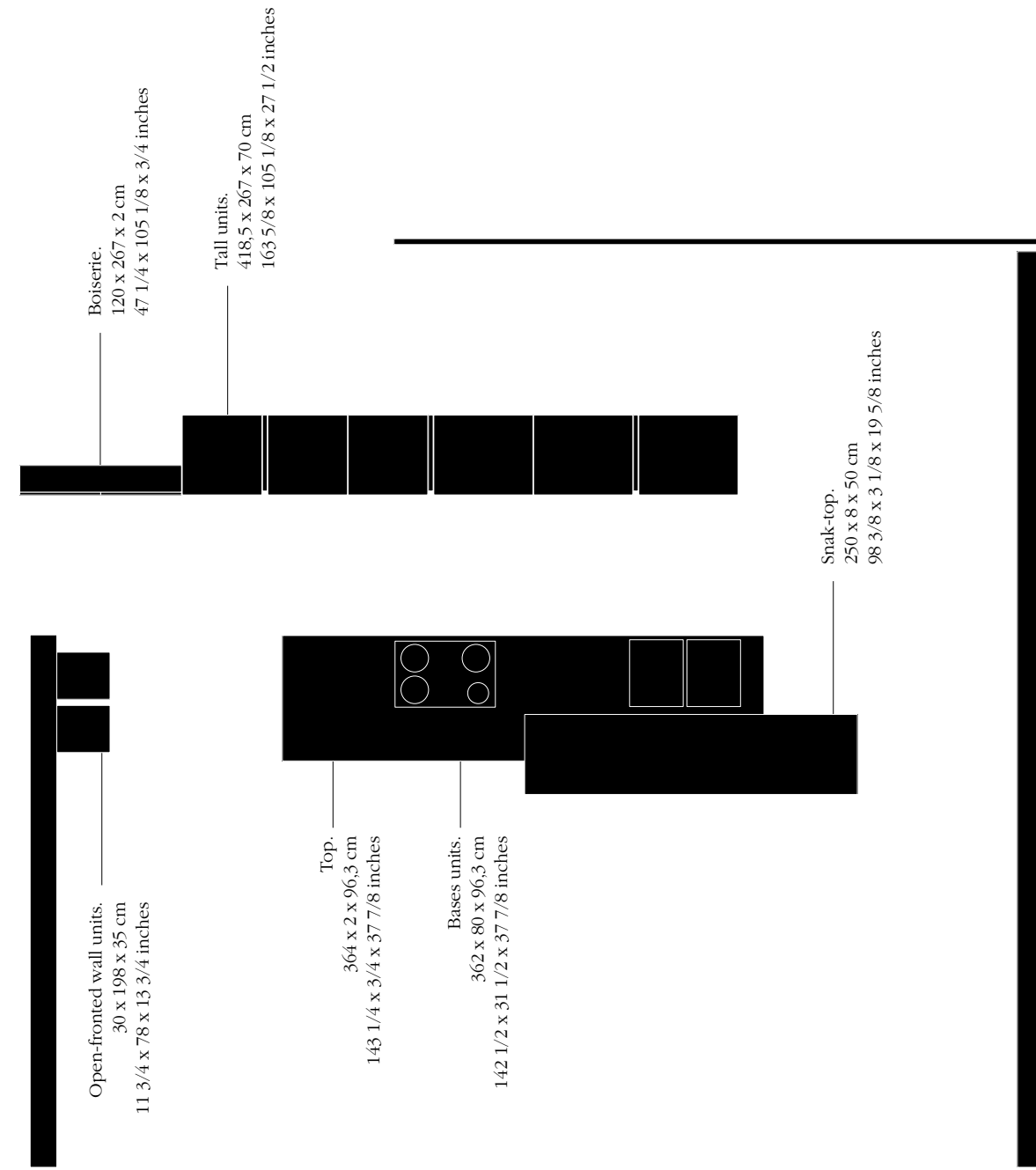



Basi altezza 80 cm laccato opaco white moon.
 Top corian® glacier white spessore 2 cm.
 Colonne rovere termotrattato.
 Elementi a giorno laccato lucido selva.
 Cappa Panel Hood laccato opaco white moon.
 A destra: estrattore con cassetto interno grigio
 antracite, attrezzatura interna rovere dark.

Matt white moon lacquered base units height 80 cm.
 Glacier white corian® top th. 2 cm.
 Heat-treated oak tall units.
 Forest gloss lacquered open-fronted units.
 Matt white moon lacquered Panel Hood.
 Right: nested-drawers with internal anthracite grey
 sections, internal fittings in dark oak.





Le basi altezza 80 cm laccato opaco
white moon sono attrezzate
con portarifiuti per la raccolta differenziata.
A destra: top corian® glacier white
con vasche lavello sottotop in acciaio.
Piano snack a sbalzo in rovere termotrattato.

The white moon matt lacquered
base units height 80 cm
are fitted with recycling bins.
Right: glacier white corian® worktop
with undermounted steel sinks.
Overhanging snack top in heat-treated oak.



Armadi e colonne in rovere termotrattato,
con ripiani interni Mix in vetro e telaio in alluminio.
A destra: armadio con colonna estraibile
attrezzata con ripiani dotati di sponde in vetro.

Cupboards and tall units in heat treated oak,
with Mix internal shelving and aluminum frame.
Right: cupboard with pull-out equipment
fitted with glass-sided shelves.

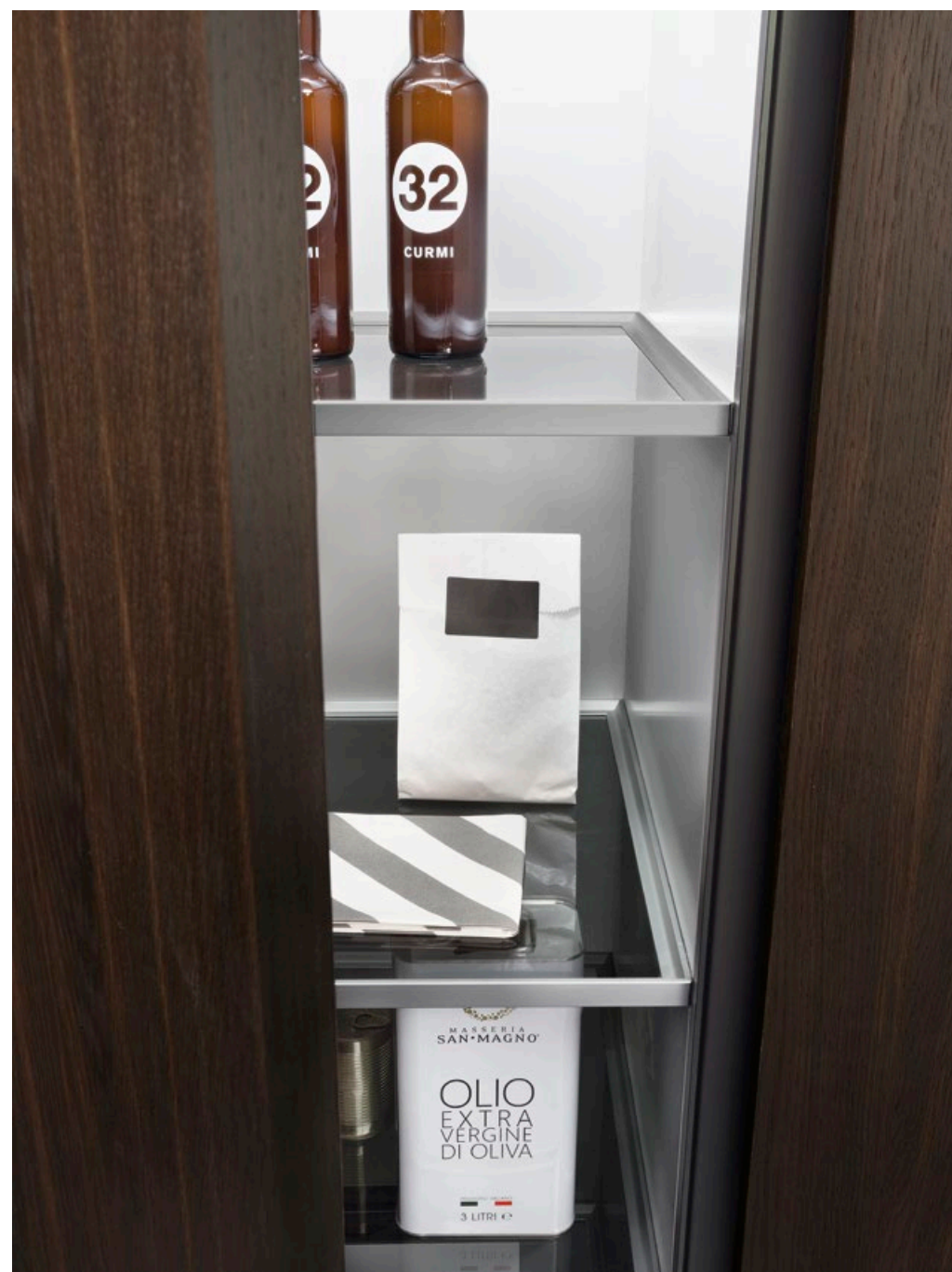



Armadio indoor con ante rientranti rovere termotrattato.
Ripiani interni in acciaio.
Schienale e cassetti rovere termotrattato.
Vano centrale con schienale e piano estraibile in acciaio.
Sistema di illuminazione serie led line.

Indoor cupboard with retracting heat-treated oak doors.
Internal steel shelves. Back panel and drawers in heat treated oak.
Central opening with back panel and pull-out top in steel.
Led line series lighting.



DOORS AND WORKTOPS

Una straordinaria gamma di finiture esclusive, dai laccati, al legno, ai vetri alle melamine hi-tech, che permette grande libertà progettuale. Una ricerca continua che offre funzionalità e soluzioni creative: essenze naturali, unicità dei marmi, materiali tecnici come l'esclusivo Iconcrete, per alte prestazioni e massima originalità.

An assortment of exclusive materials and finishes provide vast interior design potential with lacquers, woods, glass and hi-tech melamine. Continual research delivers creative functions and solutions: natural woods, the unique beauty of marble and technical materials including the exclusive Iconcrete.

DOORS

Icon*
Obliqua, One, Soul
_laccati lucidi e opachi
_matt and glossy lacquered finishings



Icon, Obliqua, One, Soul
_laccato effetto metallo satinato
_satined metal effect lacquered



* Telaio anta Air disponibile solo ed esclusivamente in versione laccato opaco anche se abbinato al pannello frontale in laccato lucido.
Air door frame only available in matt lacquered version even if combined with gloss lacquered front panel.

Icon (solo anta da 22mm / only 22mm door), Obliqua, One, Soul

_fenix ntm™ con bordo laser
_fenix ntm™, laser edge



Icon (solo anta da 22mm / only 22mm door), Obliqua, One, Soul

_laminato opaco e lucido con bordo laser
_matt and glossy laminate, laser shaped edge



Icon (solo anta da 22mm / only 22mm door), Obliqua, One, Soul

_laminato materico con bordo laser
_"textured" laminate, matt laser edge



Icon, Obliqua, One, Soul

_legno massello "Deluxe"
_"Deluxe" solid wood



Icon, Obliqua, One, Soul

_impiallacciato antico
_antique-effect veneer



Icon, Obliqua, One, Soul

_impiallacciato legno*
_wood veneer*



Obliqua, One, Soul

_hi-melamine "effetto legno" con bordo abs
_hi-melamine "wood effect" abs edge



Obliqua, One, Soul

_hi-melamine bordo laser
_hi-melamine, laser-shaped edge



* finitura liscia / smooth finish
_non disponibile per tutti i modelli
_available for all models

finitura seghettata / rough-sawn finish
_non disponibile su Olmo Caramello e Olmo Carob
_not available on Caramel Elm and Carob Elm

Obliqua, One, Soul
 _hi-melamine "effetto resina" con bordo abs
 _hi-melamine "resin-look colours" abs edge

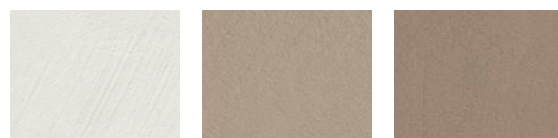

bianco camelia
camelia white

naturel
naturel

ginger
ginger

Icon (solo anta da 22mm / only 22mm door), One
 _laminato "effetto legno" con bordo abs
 _"wood effect" laminate, abs edge

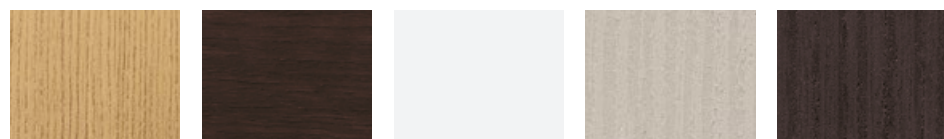

olmo safari
safari elm

rovere scuro
dark oak

larice white
white larch

larice grige
grey larch

larice brown
brown larch

Icon (solo anta da 28mm / only 28mm door)
 _corian
 _corian



vanilla

cameo white

pearl grey

bisque

glacier white

Icon (solo anta da 28mm / only 28mm door)
 _stone+
 (finitura bocciardata / bushhammered finish)

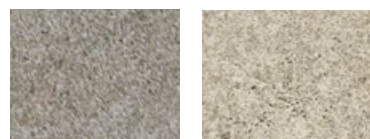

Cervino Tamac

Rock Bahama Beige

Icon (solo anta da 28mm / only 28mm door)
 _gres "Fokos"
 _"Fokos" stoneware

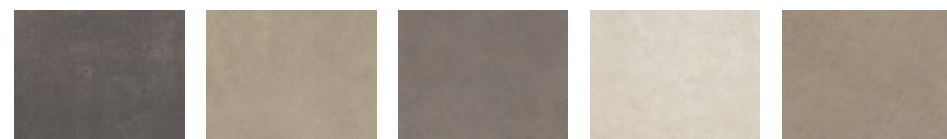

fokos piombo
fokos lead

fokos rena
fokos sand

fokos roccia
fokos rock

fokos sale
fokos salt

fokos terra
fokos earth

Icon (solo anta da 28mm / only 28mm door)
 _gres porcellanato
 _porcelain stoneware



oxide moro
oxide dark brown

oxide nero
oxide black

collection bianco
collection white

collection nero intenso
collection deep black

via tomabuoni

via montenapoleone

via farini

road



noisette

pulpisnat

amadeusnat

office

Icon
 _pietra piasentina
 (finitura fiammata, finitura leather)
 _piasentina stone
 (flamed finish, leather finish)

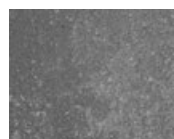

Icon (solo anta da 28mm / only 28mm door)
 _finiture vetro lucido e opaco, retro-verniciato
 _gloss and matt glass finishes with back-painting



ghiaccio
ice

bianco
white

linum

grigio rugiada
dew grey

grigio artico
arctic grey

moka

limo

Icon (solo anta da 28mm / only 28mm door)
 Pensile "Flex", armadio "Wine Stock" / "Flex" wall unit, "Wine Stock" cupboard



grigio trasparente
transparent grey

grigio satinato
satin grey

Soul
 Pensili "In line", Vetri del "Medley" / In Line wall units, Medley system glasses

_finiture vetro lucido e opaco, retro-verniciato
 _gloss and matt glass finishes with back-painting



grigio trasparente
transparent grey

riflettente chiaro
reflecting clear

Obliqua
 _biomalte spatolate e materiche
 _faux plaster and tactile finish biomalta resins



bianco
white

pietra
stone

grigio
grey

ardesia
slate

nero
black

castagna
chestnut

arenaria
sandstone

terranova
terranova

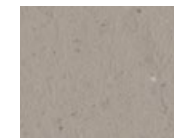

grigio siliceo
siliceous grey

One
 _finiture vetro lucido e opaco, retro-verniciato
 _gloss and matt glass finishes with back-painting



white moon
white moon

grigio seta
silk grey

cream
cream

chalk
chalk

ghisca
cast-iron

I colori non sempre corrispondono a quelli reali per comprensibili motivi di stampa. Colori e tonalità si possono visionare presso i Punti Vendita, direttamente su prodotti e campionari.

For obvious reasons relating to printing methods, colours are not always exactly as shown. Colours and shades can be viewed at our Dealers, directly on products and samples.

laminato opaco e materici matt and "textured" laminate



15 colori _ colours
spessore cm
1,2 - 2 - 4 - 6
thickness inches
1/2 - 3/4 - 1 5/8 - 2 3/8

laminato unicolor e materici unicolor and "textured" laminate



14 colori _ colours
spessore cm
2 - 3 - 22
thickness inches
3/4 - 1 1/8 - 8 5/8

acciaio steel



5 finiture _ finishes
spessore cm
1,2 - 2 - 3 - 4 - 6 - 8 - 10 - 12 - 15 - 18
thickness inches
1/2 - 3/4 - 1 1/8 - 1 5/8 - 2 3/8
3 7/8 - 4 3/4 - 5 7/8 - 8 5/8

vetro glass



21 finiture _ finishes
spessore cm
1,2
thickness inches
1/2

biomalte spatolate faux plaster biomalta resins



9 finiture _ finishes
spessore cm
2
thickness inches
3/4

fenix ntm™ fenix ntm™



11 finiture _ finishes
spessore cm
1,2 - 2 - 3 - 4 - 6
thickness inches
1/2 - 3/4 - 1 1/8 - 1 5/8 - 2 3/8

corian corian

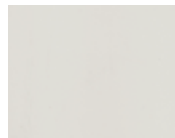

5 finiture _ finishes
spessore cm
1,2 - 2 - 2,4 - 3 - 4 - 6 - 8 - 10 - 12 - 22
thickness inches
1/2 - 3/4 - 1 1/8 - 1 5/8 - 2 3/8
3 1/8 - 3 7/8 - 4 3/4 - 8 5/8

iconcrete iconcrete



1 finiture _ finishes
spessore cm
1,2 - 2 - 3 - 4 - 6 - 8 - 10 - 22
thickness inches
1/2 - 3/4 - 1 1/8 - 1 5/8 - 2 3/8
3 1/8 - 3 7/8 - 8 5/8

quarz quartz

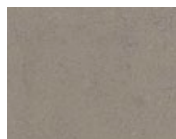

32 finiture _ finishes
spessore cm
1,2 - 2 - 3 - 4 - 6 - 8 - 10 - 15 - 18 - 22
thickness inches
1/2 - 3/4 - 1 1/8 - 1 5/8 - 2 3/8
3 1/8 - 3 7/8 - 5 7/8 - 7 1/8 - 8 5/8

marmo granito granite marble



6 finiture _ finishes
spessore cm
2 - 3 - 4 - 6 - 22
thickness inches
3/4 - 1 1/8 - 1 5/8 - 2 3/8 - 8 5/8

gres porcellanato kerlite kerlite porcelain stoneware

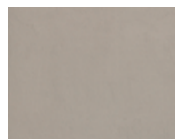

8 finiture _ finishes
spessore cm
2 - 3 - 4 - 6 - 8
thickness inches
3/4 - 1 1/8 - 1 5/8 - 2 3/8 - 3 1/8

gres porcellanato laminam laminam porcelain stoneware



9 finiture _ finishes
spessore cm
2 - 3 - 4 - 6 - 8
thickness inches
3/4 - 1 1/8 - 1 5/8 - 2 3/8 - 3 1/8

pietra piacentina piacentina stone



1 finiture _ finishes
spessore cm
2 - 3 - 4 - 6 - 8 - 10
thickness inches
3/4 - 1 1/8 - 1 5/8 - 2 3/8 - 3 1/8 - 3 7/8

stone+

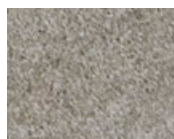

16 finiture _ finishes
spessore cm
1,2 - 3 - 4 - 6 - 8
thickness inches
1/2 - 3/4 - 1 1/8 - 1 5/8 - 2 3/8 - 3 1/8

L'etichettatura delle emissioni.

A garanzia di prodotti d'arredo a bassa emissione di sostanze nocive (Composti Organici Volatili).

L'arredamento domestico può influire direttamente sulla salubrità dell'aria che respiriamo ogni giorno fra le mura domestiche; è per questo che Ernestomeda realizza solo cucine che garantiscano la massima affidabilità e qualità, contenendo il livello degli agenti che potrebbero contaminare l'**aria indoor**. L'etichetta delle emissioni ha il compito di riportare ed informare circa il livello di VOC *Volatile Organic Compounds* (Composti Organici Volatili), che possono essere presenti nell'aria, in particolar modo negli spazi confinati. Come i prodotti alimentari o medicali, anche le emissioni indoor causate dall'arredamento possono influire sulla salute della persona, soprattutto in casi specifici come quello della Formaldeide, dichiarata cancerogena per l'uomo. Le cucine Ernestomeda garantiscono il minor impatto sulla qualità dell'aria in quanto certificate dal Laboratorio prove del Centro Tecnologico Internazionale COSMOB che, attraverso l'iter di certificazione CQP Indoor Hi-quality, effettua test valutativi per verificare il rispetto degli standard previsti dalla normativa ANSI/BIFMA M7.1-2011. L'etichetta delle emissioni attesta che le cucine Ernestomeda appartengono alla classe più virtuosa: la **A++**, in quanto è stato registrato un livello al di sotto di 0,500 mg/m³, lo stesso parametro utilizzato da uno dei protocolli più restrittivi in termini di emissione: il **regolamento americano LEED** (*Leadership in Energy and Environmental Design*). Le cucine Ernestomeda sono dunque conformi al regolamento LEED per le emissioni indoor rappresentando una garanzia anche per tutti coloro che progettano in ottica ecosostenibile. Ernestomeda rinnova il suo impegno nel garantire sempre la massima salubrità dell'ambiente indoor e permettere alle persone che lo abitano, di sentirsi libere di respirare un'**aria di qualità**.

Emissions labelling.

Guaranteeing furnishing products with low harmful substance (Volatile Organic Compound) emissions.

Home furnishings may directly affect the healthiness or otherwise of the air we breathe in our homes every day, so Ernestomeda only builds kitchens with the highest reliability and quality standards, keeping down the levels of substances which may contaminate our **indoor air**. The emissions label provides certification and information relating to the level of VOC *Volatile Organic Compounds* which may occur in the air, especially in confined spaces. Like foods or medicines, the indoor emissions caused by furnishings may also affect people's health, especially in specific cases such as that of Formaldehyde, declared carcinogenic in man. Ernestomeda kitchens guarantee the lowest impact on air quality since they are certified by the Testing Laboratory of the COSMOB International Technology Centre, which adopts the CQP Indoor Hi-Quality certification procedure for testing to verify compliance with the ANSI/BIFMA M7.1-2011 regulation standards. The emissions label certifies that Ernestomeda kitchens are in the highest class, **A++**, since the level recorded is below 0.500 mg/m³, the same parameter used by one of the strictest emissions protocols, the **American LEED** (Leadership in Energy and Environmental Design) **regulations**. Ernestomeda kitchens therefore comply with the LEED regulations on indoor emissions, and also provide guarantees to all those working in the area of sustainable design. Ernestomeda renews its commitment to always ensuring the most healthy indoor environment possible, giving people the certainty that they are free to breathe **quality air** in their homes.

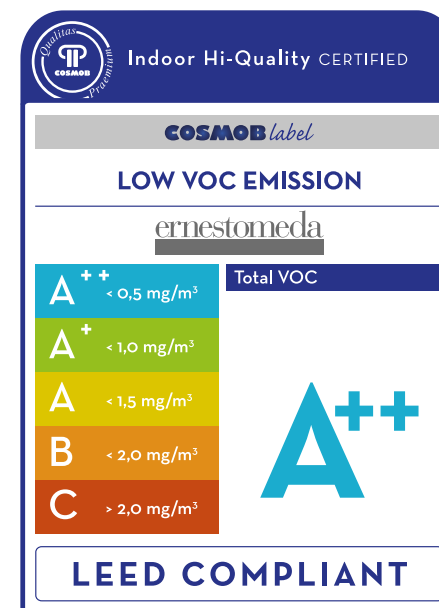

Photographer:
Santi Caleca

Photo assistant:
Thomas Pagani

Stylist:
Studiopepe

Films:
Selecolor Firenze

Print:
Tipoluce

Credits:

&Tradition, All'Origine, Another Country, Antonio Gramegna, Areti, Artemide, Atelier Areti, Atipico, Aym, Baxter, Bd Barcelona, Billiani, Bitossi Home, Bloomingville, Bonaldo, Bormioli Rocco, Bosa, Braun, Busnelli, Caffè Vergnano, Calligaris, Carpet Edition, Catellani&Smith, Coltellerie Berti, Colli Ripani, Corrado Corradi, Discipline, Elena Salmistraro, Enginux, Fabbian, Fabrica, Ferm Living, Fiammetta Marble, Flos, Fontanarte, Galleria Cappellini, Gallotti e Radice, Gift Company, Gio Tiroto, GT Design, Hachiman, I+I, House Doctor, Iittala, Ilaria Innocenti, Incipit Lab, Indikon, Ittala, Jacob Jensen, James Stocklund, Karpeta, Kenwood, Kitchen Aid, Kristalia, L'Interno by Franco Fabbri (tessuto tenda), Labour and Wait, Le Creuset, Lema, Lexon, L'Interno, Lineasette, Lithho Ceramic, Little Owl, Livia Polidoro, Living Divani, Mani ceramiche, Marco Guazzini, Marmo In, Massimo Caiazzo, Matthias Kaiser, Mattiazzi, Mdf, Menu, Mepra, Meridiani, Miniforms, Mohebban, Mulino Marino, Normann Copenhagen, Olio Roi, Penta, Pimar, Plank, Prandina, Riess, Rummo, S. Benedetto, Saba, Sambonet, Scandola Marmi, Segno Italiano, Sharona Merlin, Stelton, Thonet, Uno Design, Valia Barriello, Vesoi, Vetreria Etrusca, Vetruria, Vibia, Vino Manaresi, Vistosi, Vitra, Zafferano, Zero Lighting, Zilio Aldo

Ernestomeda ha dato il vita a EMvironment, un progetto che pone il rispetto dell'ambiente al centro della filosofia produttiva aziendale. L'ecosostenibilità non è più solo una parola ma un atteggiamento responsabile: siamo energicamente autosufficienti grazie ad un impianto fotovoltaico che copre 16.000 metri quadrati di superficie e ha una potenza di 1,2 MWP. Questo ci permette di evitare l'emissione di circa 722.160 kg di anidride carbonica l'anno, pari a quella assorbita da 93.800 alberi. Ernestomeda has established EMvironment, a project that places environmental protection at the centre of the company's production philosophy. Environmental sustainability is not just a verbal mantra but a genuine responsible approach: we are self-sufficient in energy thanks to a photovoltaic system 16,000 square metres in area, with a generation capacity of 1.2 MWP. This enables us to avoid the emission of about 722,160 kg of carbon dioxide a year, the quantity absorbed by 93,800 trees.

Ernestomeda è dotata di un Sistema di Gestione della Qualità UNI EN ISO 9001, un Sistema di Gestione Ambientale UNI EN ISO 14001 e un Sistema di Gestione Salute e Sicurezza OHSAS 18001.

Tutti i Sistemi sono stati certificati dall'Ente Internazionale SGS.

Ernestomeda has a Quality Management System compliant with the UNI EN ISO 9001 standard, a UNI EN ISO 14001 Environmental Management System and an OHSAS 18001 Occupational Health and Safety Management System. All Systems are certified by the international notified body SGS.

